



Fire Your Imagination

Small Marlborough, Stockton & Steel Manhattan

Balanced Flue with Upgradeable Control Valve



Instructions for Use, Installation & Servicing

For use in GB & IE (Great Britain & Republic of Ireland).

IMPORTANT

THE OUTER CASING, FRONT AND GLASS PANEL BECOME EXTREMELY HOT DURING OPERATION AND WILL RESULT IN SERIOUS INJURY AND BURNS IF TOUCHED. IT IS THEREFORE RECOMMENDED THAT A FIREGUARD COMPLYING WITH BS 8423 (LATEST EDITION) IS USED IN THE PRESENCE OF YOUNG CHILDREN, THE ELDERLY OR INFIRM.

This product contains a heat resistant glass panel. This panel should be checked during Installation and at each servicing interval. If any damage is observed on the front face of the glass panel (scratches, scores, cracks or other surface defects), the glass panel must be replaced and the appliance must not be used until a replacement is installed. Under no circumstances should the appliance be used if any damage is observed, the glass panel is removed or broken.

It is essential that ALL of the screws/ nuts that retain the door are replaced and tightened correctly. Under no circumstances should the appliance be operated if any of these screws/ nuts are loose or missing.

These Instructions must be left with the appliance for future reference and for consultation when servicing the appliance. Please make the customer aware of the correct operation of the appliance before leaving these instructions with them.

The commissioning sheet found on Page 3 of this Instruction manual must be completed by the Installer prior to leaving the premises.

Contents

Small Marlborough, Stockton & Steel Manhattan - Balanced Flue

In a range of colours, see page 10 for details.

Appliance Commissioning Checklist	3
User Instructions	4
Installation Instructions	10
Technical Specifications	10
Site Requirements	12
Installation	15
Commissioning	21
Servicing Instructions.....	22
Fault Finding.....	22
How to Replace Parts	24
Spare Parts List.....	29
Service Records	33



If you have purchased your stove or fire from an authorised stockist within our Expert Retailer Network, then automatically your product will carry a 2 year warranty as standard. The 2 year warranty can be further extended to a total warranty period of 5 years by registering your Gazco Stove or Fireplace within one month of the latter of the purchase date or installation date. Accordingly, the start date for the warranty period is the date of purchase. During the registration process, the Expert Retailer details will be required for your Extended Warranty to be activated. Any product purchased outside of our Expert Retailer Network will carry a standard 12 month, non-extendable warranty.

It is a condition of the Extended Warranty that the installation complies with the relevant Building Regulations and is carried out by a suitably trained and qualified individual (GasSafe in the UK or equivalent in other countries) with the certificate of installation and the Commissioning Report on Page 3 completed and retained by the end user.

Full terms and conditions are detailed in the Warranty Statement on the Gazco website. In the event of any conflict of information the wording on the website shall prevail.

Important Note: Should any problems be experienced with your product, claims must first be submitted to the Expert Retailer where the appliance was purchased from who will offer immediate assistance or contact Gazco on your behalf.



It is a requirement of the Building Regulations 2010 that the installation of this appliance is notified to the Local Authority. It is the responsibility of the GasSafe registered installer to carry out this notification to the Local Authority via the GasSafe register Competent Persons Scheme in England and Wales (different rules apply in Scotland and Northern Ireland).

When the installation has been notified, GasSafe will send a Building Regulations Compliance Certificate to you containing details of the work completed. Please ensure that the person responsible for the installation of this appliance completes this notification and records it in the Appliance Commissioning Checklist on page 3.

IT IS YOUR RESPONSIBILITY TO COMPLY WITH THE BUILDING REGULATIONS AND BE ABLE TO PRODUCE THIS CERTIFICATE SHOULD IT BE REQUIRED IN THE FUTURE.

Appliance Commissioning Checklist

To assist us in any guarantee claim please complete the following information:-

IMPORTANT NOTICE

Explain the operation of the appliance to the end user, hand the completed instructions to them for safe keeping, as the information will be required when making any guaranteed claims.

FLUE CHECK	PASS	FAIL	
1. Flue Is correct for appliance			
2. Flue flow Test N/A			
3. Spillage Test N/A			
GAS CHECK			
1. Gas soundness & let by test			
2. Standing gas pressure	mb		
3. Appliance working pressure (on High Setting) NB All other gas appliances must be operating on full	mb		
4. Gas rate	m ³ /h		
5. Does Ventilation meet appliance requirements N/A			
6. Have controls been upgraded (Upgradeable models only)	8455 Standard	YES	NO
	8456 Programmable Thermostatic and Timer	YES	NO
SAFETY CHECK			
1. Glass checked to ensure no damage, scratches, scores or cracks.			
2. Door secured correctly and all screws/ nuts replaced			
BUILDING CONTROL NOTIFICATION	YES	NO	
1. Installer notified GasSafe/Local Authority of installation via Competent Persons Scheme?			

RETAILER AND INSTALLER INFORMATION

Retailer	Installation Company
Contact No.	Engineer
Date of Purchase	Contact No.
Model No.	GasSafe Reg No.
Serial No.	Date of Installation
Gas Type	

User Instructions

Welcome

Congratulations on purchasing your Gazco Stove, if installed correctly Gazco hope it will give you many years of warmth and pleasure for which it was designed.

The purpose of this manual is to familiarise you with your appliance, and give guidelines for its installation, operation and maintenance. If, after reading, you need further information, please do not hesitate to contact your Gazco retailer.

WARNING



In the event of a gas escape or if you can smell gas, please take the following steps:

- Immediately turn off the gas supply at the meter/emergency control valve
- Extinguish all sources of ignition
- Do not smoke
- Do not operate any electrical light or power switches (On or Off)
- Ventilate the building(s) by opening doors and windows
- Ensure access to the premises can be made

Please report the incident immediately to the National Gas Emergency Service Call Centre on 0800 111 999 (England, Scotland and Wales) , 0800 002 001 (N. Ireland) or in the case of LPG, the gas supplier whose details can be found on the bulk storage vessel or cylinder.

The gas supply must not be used until remedial action has been taken to correct the defect and the installation has been recommissioned by a competent person.

1. General



IMPORTANT: ALWAYS WEAR THE GLOVES PROVIDED WHEN HANDLING AN IVORY PAINTED APPLIANCE.

- 1.1 Installation and servicing must only be carried out by a competent person whose name appears on the GasSafe register. To ensure the engineer is registered with GasSafe they should possess an ID Card carrying the following logo:



- 1.2 In all correspondence, please quote the appliance type and serial number which can be found on the data badge located at the rear of the appliance.
- 1.3 **Do not** place curtains above the appliance: You must have 300mm (1') clearance between the appliance and any curtains at either side.
- 1.4 The manufacturer considers the full outer casing of this appliance to be a working surface and it will become hot whilst in operation. A suitable guard is recommended to protect young children, the aged and the infirm.
- 1.5 No furnishings or other objects should be placed within 1 metre of the front of the appliance.
- 1.6 If a shelf is fitted, a distance of 225mm above the appliance is required.
- 1.7 Do not attempt to burn rubbish in this appliance.
- 1.8 This appliance must only be operated with the door secured firmly in position. If any cracks appear in the glass the appliance must not be used until the glass panel is replaced.
- 1.9 If, for any reason, the flue has to be removed from the appliance, the seals must be replaced in the inner spigot.
- 1.10 Do not obstruct the flue terminal in any way i.e. by planting flowers, trees shrubs etc. in the near vicinity, or by leaning objects up against the terminal guard.
- 1.11 Do not put any objects on the terminal guard; it will lose its shape.
- 1.12 Do not use a garden sprinkler or hose near the terminal.
- 1.13 This product is guaranteed for 5 years from the date of installation, as set out in the terms and conditions of sale between Gazco and your local Gazco retailer. Please consult with your local Gazco retailer if you have any questions. In all correspondence always quote the Model Number and Serial Number.

2. Operating the Appliance

- 2.1 Locate the control valve on the appliance. It has two controls, see Diagram 1:
1. The right-hand knob controls the pilot ignition.
 2. The left-hand knob controls the main burner.

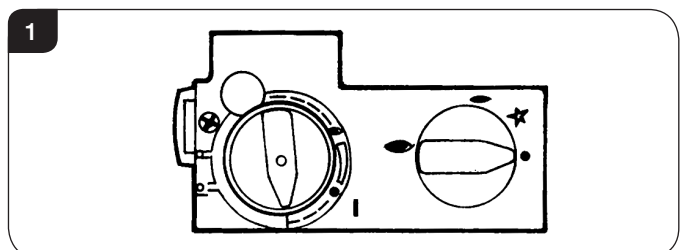

- 2.2 Refer to separate instructions if your appliance is upgraded to include battery remote control. The instructions below apply whether or not you have the remote upgrade.

User Instructions

Lighting the Pilot

- 2.3 To start the left-hand and right-hand control knobs must both point to off (●):
- 2.4 Press in the right-hand control knob and rotate anti-clockwise until a click is heard. Continue to press in. The knob points to the pilot (←).
- The pilot is lit.
- 2.5 Keep the knob depressed for 10 seconds before releasing. The pilot remains lit.
- Repeat the above steps if the pilot does not stay lit.
- NOTE: If the pilot goes out, the Interlock system prevents you lighting again for a short period.**
- 2.6 If, after repeating the above steps the pilot does not light, contact your Retailer or Installer.
- 2.7 Turn the right-hand knob to the left to main burner setting (↶).

Adjusting the Flame height

- 2.8 You can now adjust the flame height and temperature using the left-hand control knob.
- 2.9 Turn the left-hand knob anti-clockwise to increase the flame height.
- 2.10 Turn clockwise to decrease the height.

i **IMPORTANT: YELLOW FLAMES TYPICALLY APPEAR WHEN THE APPLIANCE HAS REACHED NORMAL OPERATING TEMPERATURE. THIS CAN TAKE UP TO 30 MINUTES.**

! **WARNING: IF THE APPLIANCE FAILS TO LIGHT OR BECOMES EXTINGUISHED IN USE, WAIT 3 MINUTES BEFORE ATTEMPTING TO RELIGHT.**

3. Turning OFF the Appliance

- 3.1 To turn the main burner off turn the left-hand knob until it points to off (●). Just the pilot remains lit.
- 3.2 Press in and turn the right-hand knob until it points to off (●). The pilot goes out.

4. Upgrading the Appliance

- 4.1 The appliance is fitted with a control valve that can easily be upgraded to battery powered remote control. There are two versions of this control which can be obtained through your local Gazco retailer. There is no requirement for this upgrade to be carried out by an approved GasSafe engineer. However Gazco recommend that this task is undertaken by a suitably competent person.
- 4.2 This upgrade can be fitted before or after installation but if side clearances are limited then it will be easier to upgrade the appliance before installation. Full instructions are included with the kit.

Standard Remote Control (PART NUMBER 8455)

- 4.3 This remote control can control the gas appliance after the pilot has been lit. It can turn the main burner on and regulate it from low through to high and back again. It can turn the main burner off leaving the pilot burning.

Thermostatic and Timer Remote Control (PART NUMBER 8456)

- 4.4 This remote control can control the gas appliance after the pilot has been lit.

MANUAL MODE

Can be used to turn the main burner on and manually regulate it from low through to high and back again. It can also be used to turn the main burner off leaving the pilot burning.

AUTO MODE

Will automatically regulate the room to a pre-set temperature.

TIMER MODE

Will turn the appliance on and off according to a pre-set programme and automatically regulate the room temperature during the two on periods.

5. Cleaning the Appliance

! **WARNING: NEVER CLEAN THE APPLIANCE WHILE IT'S HOT. THE APPLIANCE STAYS HOT FOR A LONG TIME AFTER SHUTDOWN.**

IMPORTANT: THE OUTER PANNELLING AND DOOR OF THE APPLIANCE IS MADE FROM CAST IRON OR STEEL. TAKE CARE WHEN INSTALLING, REMOVING AND STORING TO AVOID DAMAGING THE OUTER CASING, HEARTH OR DOOR.

Marlborough & Stockton

- 5.1 Remove the cast iron door by removing the 4 dome nuts retaining the door. Place carefully to one side.

2

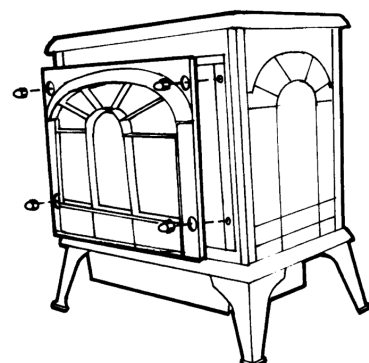

User Instructions

- 5.2 Carefully remove the ceramic fuel bed components and set aside. Protect floor coverings and follow the advice in Section 7.
- 5.3 The logs should not require cleaning. Do not use a vacuum cleaner or brush to clean the logs, any large pieces of debris may be removed by hand.
- 5.4 Ensure any debris is removed from the burner ports.
- 5.5 Replace the ceramics, see Section 8.
- 5.6 Ensure that the rope seal on the back of the door is intact, locate the door on the 4 studs and slide back to the firebox. Secure in place using the 4 dome nuts. Do not over tighten the nuts, see Diagram 2.

NEVER OPERATE THE APPLIANCE WHEN THE DOOR IS REMOVED, OR THE GLASS IS BROKEN.

- 5.7 Replace ALL of the securing nuts ensuring that a nut is present on all fixing studs.

! UNDER NO CIRCUMSTANCES SHOULD THE APPLIANCE BE USED IF ANY OF THE DOOR RETAINING NUTS ARE LOOSE OR MISSING.

- 5.8 Use a damp cloth to clean the outer casing of the appliance.

Steel Manhattan

! THE GLASS FRAME IS FRAGILE. TAKE CARE WHEN HANDLING TO AVOID DAMAGE.

- 5.9 To remove the glass frame lift off the decorative steel trim, see Diagram 3.

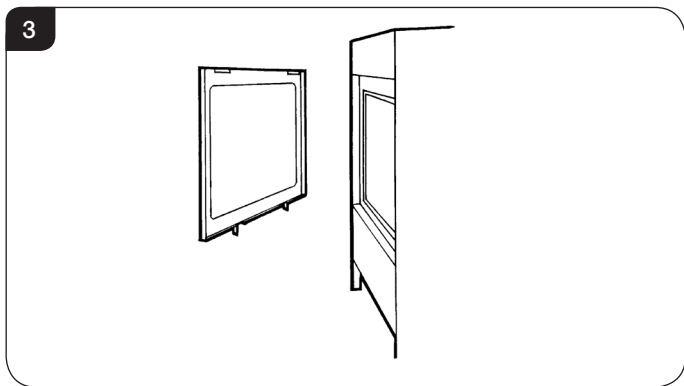

- 5.10 Remove the 8 screws holding the glass frame, see Diagram 4. Take care to support the glass when removing the screws.

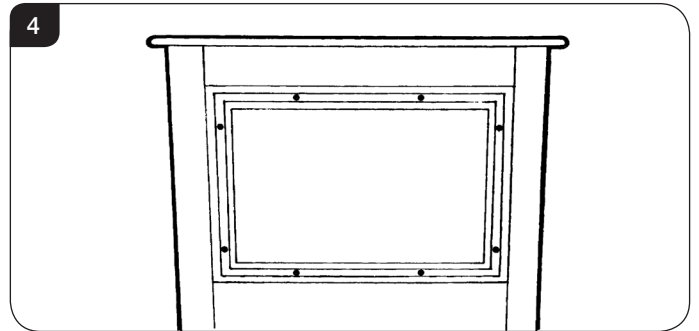

- 5.11 Remove the glass frame and place carefully to one side.
- 5.12 Carefully remove the ceramic fuel bed components and set aside. Protect floor coverings and follow the advice in Section 7.
- 5.13 The logs should not require cleaning. Do not use a vacuum cleaner or brush to clean the logs, any large pieces of debris may be removed by hand.
- 5.14 Ensure any debris is removed from the burner ports.
- 5.15 Replace the ceramics, see Section 8.
- 5.16 Refit in reverse order.
- 5.17 Ensure that the rope seal on the back of the door is intact. Replace the glass frame and tighten the 8 screws, see Diagram 4.
- 5.18 Offer the decorative steel trim to the opening, inserting the 2 tags on the bottom of the trim behind the bottom panel. Lift the top of the trim up and hook the lugs on the back of the trim over the top of the glass frame, see Diagram 5.

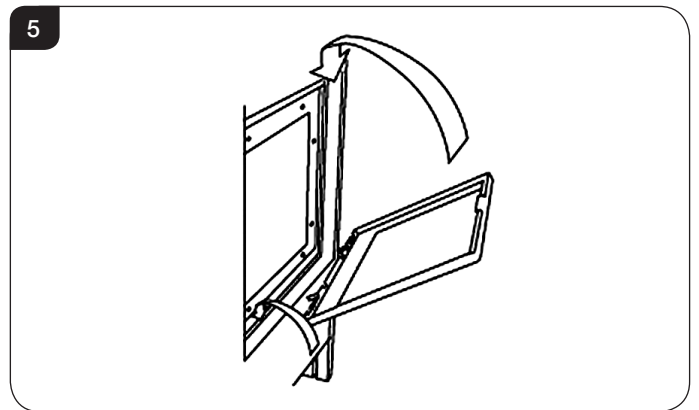

NEVER OPERATE THE APPLIANCE WHEN THE GLASS FRAME IS REMOVED, OR THE GLASS IS BROKEN.

- 5.19 Replace ALL of the securing screws ensuring that a screw is present in all fixing slots.

! UNDER NO CIRCUMSTANCES SHOULD THE APPLIANCE BE USED IF ANY OF THE DOOR RETAINING SCREWS ARE LOOSE OR MISSING.

- 5.20 Use a damp cloth to clean the outer casing of the appliance.

User Instructions

6. Cleaning Ivory Painted Appliances

- 6.1 **Allow appliance to cool thoroughly to avoid risk of burns.**
- 6.2 Ivory painted appliances require special attention when cleaning. They have been coated with a high quality paint that should give many years of service. However, this colour will mark more easily and require cleaning more than other models.
- 6.3 Take care when touching the appliance to avoid marking the paint. Most marks can be removed using a mild soap solution and a clean lint free cloth. The finish can also be refreshed using aerosol touch up paint (product code 2055) available from your Gazco retailer.

7. Arrangement of Fuel Bed

Advice on handling and disposal of fire ceramics



The fuel effect and side panels in this appliance are made from Refractory Ceramic Fibre (RCF), a material which is commonly used for this application.

Protective clothing is not required when handling these articles, but we recommend you follow normal hygiene rules of not smoking, eating or drinking in the work area and always wash your hands before eating or drinking.

To ensure that the release of RCF fibres are kept to a minimum, during installation and servicing a HEPA filtered vacuum is recommended to remove any dust accumulated in and around the appliance before and after working on it. When servicing the appliance it is recommended that the replaced items are not broken up, but are sealed within heavy duty polythene bags and labelled as RCF waste.

RCF waste is classed as stable, non-reactive hazardous waste and may be disposed of at a licensed landfill site.

Excessive exposure to these materials may cause temporary irritation to eyes, skin and respiratory tract; wash hands thoroughly after handling the material.

8. Log Layout



WARNING: NEVER CLEAN THE APPLIANCE WHILE IT'S HOT. THE APPLIANCE STAYS HOT FOR A LONG TIME AFTER SHUTDOWN.

IMPORTANT: THE OUTER PANELLING AND DOOR OF THE APPLIANCE IS MADE FROM CAST IRON OR STEEL. TAKE CARE WHEN INSTALLING, REMOVING AND STORING TO AVOID DAMAGING THE OUTER CASING, HEARTH OR DOOR.

Marlborough & Stockton

- 8.1 Remove the cast iron door by removing the 4 dome nuts retaining the door. Place carefully to one side, see Diagram 2.

Steel Manhattan



THE GLASS FRAME IS FRAGILE. TAKE CARE WHEN HANDLING TO AVOID DAMAGE.

- 8.2 To remove the glass frame lift off the decorative steel trim, see Diagram 3.
- 8.3 Remove the 8 screws holding the glass frame, see Diagram 4. Take care to support the glass when removing the screws.
- 8.4 Remove the glass frame and place carefully to one side.

All Models

- 8.5 There are 4 logs, each with an identification letter, A, B, C and D. Log C has an arrow on the underside to indicate its orientation. The arrow points towards the rear of the appliance.
- 8.6 Place the largest Log A on the burner with the location legs on the underside against the stops on the rear of the burner skin, see Diagram 6.

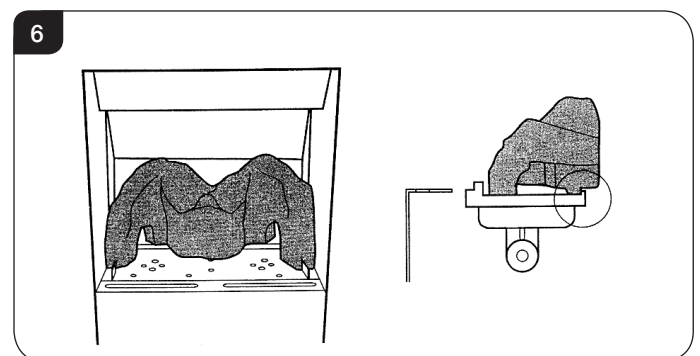

User Instructions

- 8.7 Place the rear face of log B against the stops on the front of the burner skin. The front of the log will rest on the firebox behind the 2 slots, see Diagram 7.

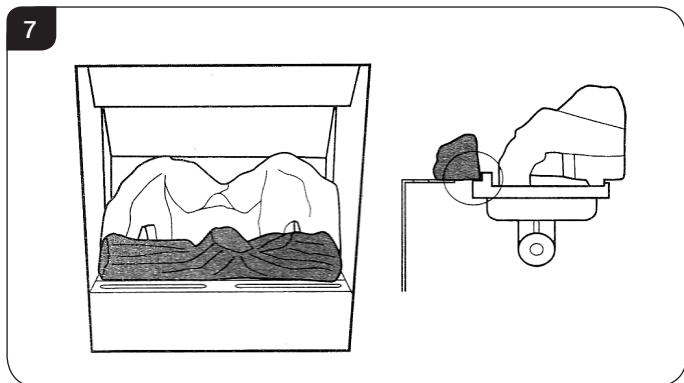

- 8.8 Place log C with the arrow pointing towards the rear of the appliance. The front of the log will rest in the hollow on the left-hand side of log B. The rear of the log will locate in the left-hand hollow on log A, see Diagram 8.

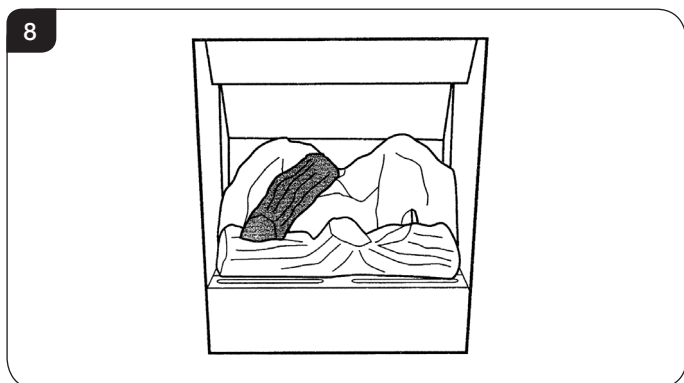

- 8.9 Log D is placed with the Y shaped branch towards the front of the appliance. There is a cutout on the top right hand side of the front log (B). Locate the right hand branch of log D in this cut-out and rest the top of the log in the location of log A, see Diagram 9.

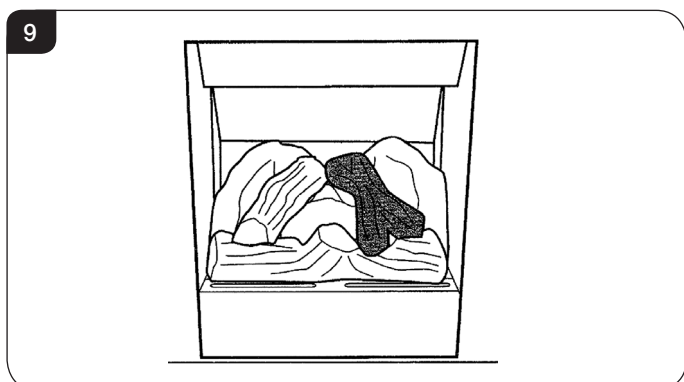

NOTE: ENSURE THAT LOGS ARE POSITIONED AS DETAILED ABOVE.

- 8.10 Replace the door, see Section 9.

9. Replacing the Door

Marlborough & Stockton

- 9.1 Ensure that the rope seal on the back of the door is intact, locate the door on the 4 studs and slide back to the firebox. Secure in place using the 4 dome nuts. Do not over tighten the nuts, see Diagram 10.

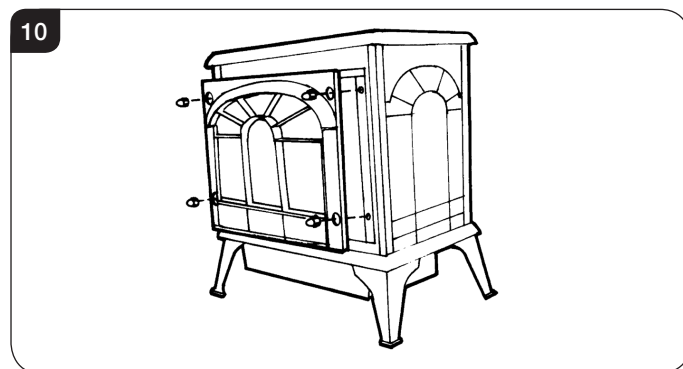

NEVER OPERATE THE APPLIANCE WHEN THE DOOR IS REMOVED, OR THE GLASS IS BROKEN.

- 9.2 Replace ALL of the securing nuts ensuring that a nut is present on all fixing studs.



UNDER NO CIRCUMSTANCES SHOULD THE APPLIANCE BE USED IF ANY OF THE DOOR RETAINING NUTS ARE LOOSE OR MISSING.

Steel Manhattan

- 9.3 Refit in reverse order.
- 9.4 Ensure that the rope seal on the back of the door is intact. Replace the glass frame and tighten the 8 screws, see Diagram 4.
- 9.5 Offer the decorative steel trim to the opening, inserting the 2 tags on the bottom of the trim behind the bottom panel. Lift the top of the trim up and hook the lugs on the back of the trim over the top of the glass frame, see Diagram 11.

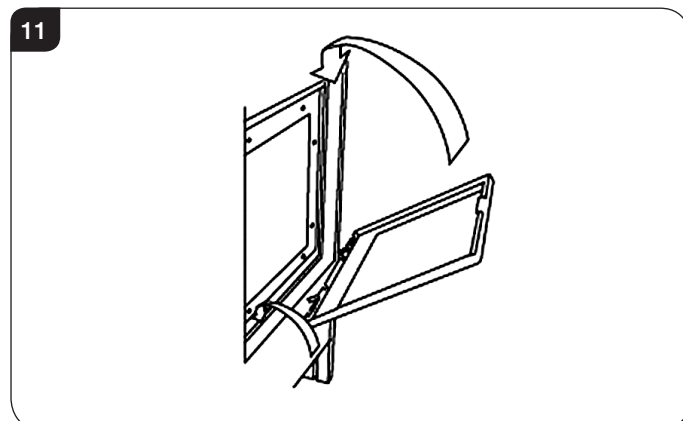

User Instructions

NEVER OPERATE THE APPLIANCE WHEN THE GLASS FRAME IS REMOVED, OR THE GLASS IS BROKEN.

- 9.6 Replace ALL of the securing screws ensuring that a screw is present in all fixing slots.



UNDER NO CIRCUMSTANCES SHOULD THE APPLIANCE BE USED IF ANY OF THE FRAME RETAINING SCREWS ARE LOOSE OR MISSING.

10. Flame Failure Device

- 10.1 This is a safety feature incorporated on this appliance which automatically switches off the gas supply if the pilot goes out and fails to heat the thermocouple.

IF THIS OCCURS DO NOT ATTEMPT TO RELIGHT THE APPLIANCE FOR 3 MINUTES.

11. Running In

- 11.1 During initial use of a new Gazco appliance a strong odour will be encountered as various surface coatings become hot for the first time. Although these odours are harmless it is recommended that the appliance is operated on maximum for 4 to 8 hours in order to fully burn off these coatings. After this period the odours should then disappear.

If the odours persists, please contact your installer for advice.

- 11.2 During the first few hours of burning there may be discolouration of the flames. This will also disappear after a short period of use.

12. Servicing

- 12.1 The appliance must be serviced every 12 months by a qualified GasSafe Engineer. In all correspondence always quote the Model number and the Serial number which may be found on the Commissioning Checklist (Page 3).

13. Ventilation

- 13.1 This appliance requires no additional ventilation.

14. Installation Details

- 14.1 Your installer should have completed the commissioning sheet at the front of this book. This records the essential installation details of the appliance. In all correspondence always quote the Model number and Serial number.

15. Hot Surfaces

- 15.1 Parts of this appliance become hot during normal use. Regard all parts of the appliance as a working surface, except for the control access panel.
- 15.2 Provide a suitable fire guard to protect young children and the infirm.

Installation Instructions

Technical Specification

Covering the following models:

	Steel Manhattan		Marlborough		Stockton	
	NG	LPG	NG	LPG	NG	LPG
Black	-	-	8536	P8536	8540	P8540
Anthracite	8622AN	P8622AN	-	-	-	-
Brushed Stainless Steel	8622BS	P8622BS	-	-	-	-

Model	Gas Cat	Gas Type	Working Pressure	Aeration	Injector	Gas Rate m ³ /h	Input kW (Gross)		Country
							High	Low	
8536/ 8540/ 8622 (all versions)	I ₂ H	Natural G20)	20mbar	9mm x 15mm	225	0.344	3.65	2.25	GB, IE
P8536/ P8540 / P8622 (all versions)	I ₃ +	Propane (G31)	37mbar	16mm x 23mm	95	0.135	3.65	2.25	GB, IE
		Butane (G30)	29mbar	2 x 16mm x 23mm					
Rear Exit Wall Thickness - Min 200mm/ Max 590mm									
Efficiency Class 2 - 78%									
Flue Outlet Size 100 Ø / Flue Inlet Size ø 150mm									
Gas Inlet Connection Size 8mm ø									

i The net efficiency of this appliance has been measured as specified in EN613:2001 and the result after conversion to gross using the appropriate factor from Table E4 of SAP 2009 is 71.8%. The test data has been certified by Kiwa Nederland BV. The gross efficiency value may be used in the UK Government's Standard Assessment Procedure (SAP) for energy rating of dwellings.

Installation Instructions

Technical Specification

This appliance has been certified for use in countries other than those stated. To install this appliance in these countries, it is essential to obtain the translated instructions and in some cases the appliance will require modification. Contact Gazco for further information.

PACKING CHECKLIST

Qty Description	Fixing Kit containing:-
1 x Appliance	1 x Instruction manual
1 x Flue Blanking plate	1 X Wood screw
1 x Log Guard	1 x Wallplug
1 x 4 Logs	1 x Box Spanner

Stockton

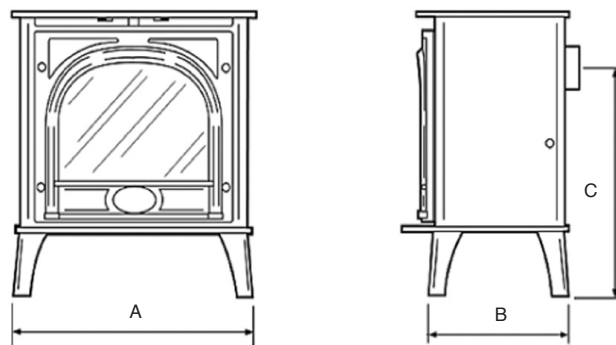

Marlborough

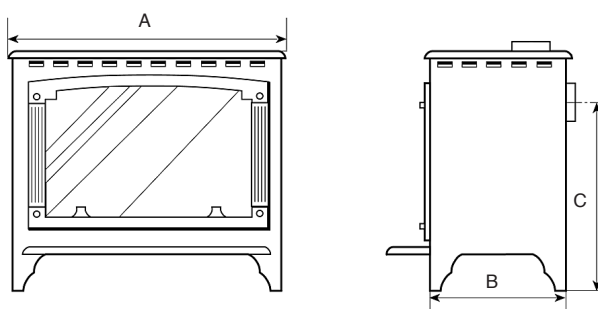

Manhattan

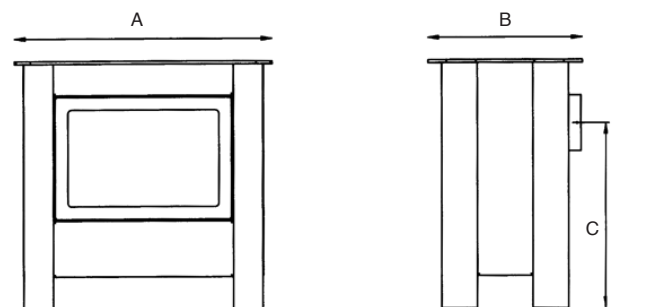

	Marlborough	Stockton	Manhattan
A	410mm	422mm	540mm
B	280mm	290mm	360mm
C	370mm	366mm	425mm

Installation Instructions

Site Requirements

1. Flue and Chimney Requirements

Note: This appliance must only be installed with the flue supplied.

You must adhere to the following:

- 1.1 The flue must be sited in accordance with BS5440: Part 1 (latest edition), see Diagram 1.
- 1.2 Fit a guard to protect people from any terminal less than 2 metres above any access such as level ground, a balcony or above a flat roof.
- 1.3 All vertical and horizontal flues must be securely fixed and fire precautions followed in accordance with local and national codes of practice.
- 1.4 A restrictor may be required. Refer to Technical Specifications on page 10.

2. Timber Framed Buildings

- 2.1 To prevent a fire hazard, you must provide additional clearance when the appliance passes through a wall containing any combustible materials.
- 2.2 A steel sleeve must be inserted into the hole through which the flue passes to give an air gap of 25mm between the sleeve and any outside surface of the flue.
- 2.3 Contact your local buildings authority for further guidance on installing gas fires in timber framed buildings.

Note: Make sure you provide adequate clearance at the sides and back of the appliance for servicing access.

1 UK Dimensions

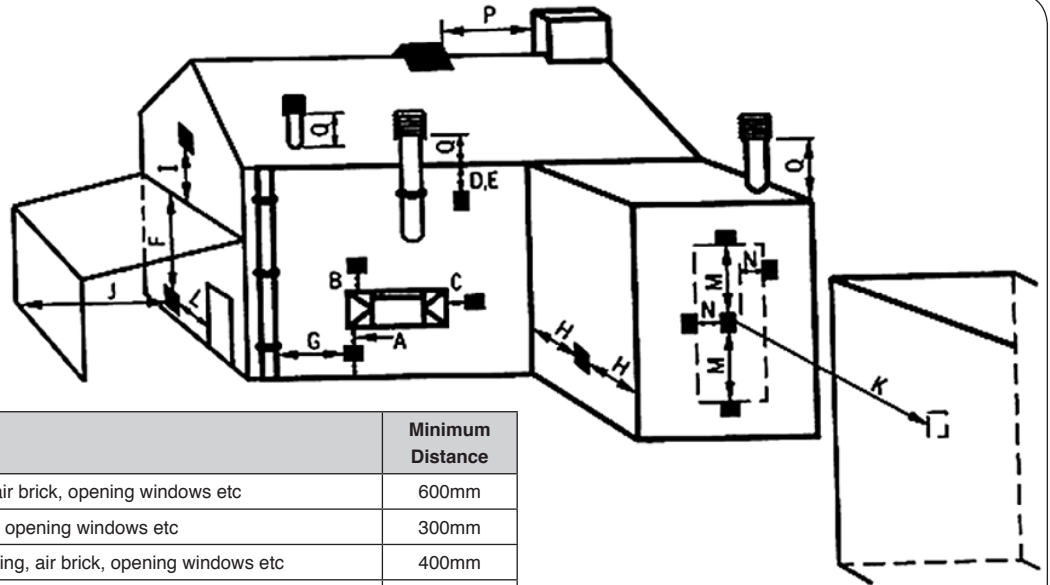

Dimension	Terminal Position	Minimum Distance
A*	Directly below an opening, air brick, opening windows etc	600mm
B*	Above an opening, air brick, opening windows etc	300mm
C*	Horizontally next to an opening, air brick, opening windows etc	400mm
D	Below gutters, soil pipes or drain pipe	300mm
E	Below eaves	300mm
F	Below balcony or car port roof	600mm
G	From a vertical drain pipe or soil pipe	300mm
H	From an internal or external corner	600mm
I	Above group roof or balcony level	300mm
J	From a surface facing the terminal	600mm
K	From a terminal facing the terminal	600mm
L	From an opening in the car port (e.g. door, window) into the dwelling	1200mm
M	Vertically from a terminal on the same wall	1500mm
N	Horizontally from a terminal on the same wall	300mm
O	From the wall on which the terminal is mounted	N/A
P	From a vertical structure on the roof	600mm
Q	Above intersection with roof	300mm

* In addition, the terminal should not be nearer than 300mm to an opening in the building fabric formed for the purpose of accommodating a built-in element such as a window frame.

Installation Instructions

Site Requirements

3. Rear Flue (8526)

2

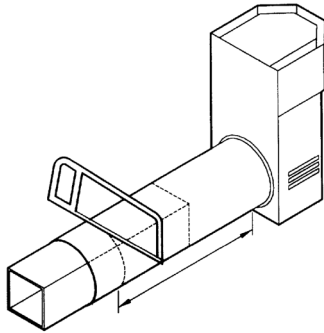

Terminal dimensions:
395 x 200 x 200 mm (H x W x D)
Guard supplied
Cut to length as required on site, see Diagram 2.

4. Ventilation

The appliance requires no additional ventilation.

5. Gas Supply

THIS APPLIANCE IS INTENDED FOR USE ON A GAS INSTALLATION WITH A GOVERNED METER.

- 5.1 Before installation, ensure that the local distribution conditions (identification of the type of gas and pressure) and the adjustment of the appliance are compatible.
- 5.2 Ensure the gas supply delivers the required amount of gas and is in accordance with the rules in force.
- 5.3 Soft copper tubing and soft soldered joints can be used but must not be closer than 50mm (2") to the underside of the firebox.
- 5.4 A means of isolating the gas supply to the appliance must be provided independent of any appliance control.
- 5.5 All supply gas pipes must be purged of any debris that may have entered prior to connection to the appliance.
- 5.6 The gas supply must be installed in a way that does not restrict the removal of the appliance for servicing and inspection.

6. Appliance Location

- 6.1 Building Regulations state this appliance must stand on a non-combustible hearth that is at least 12mm thick and projects 50mm minimum from the base of the appliance in all directions, however Gazco recommend the hearth extends to the following dimensions, see Diagram 3.

3

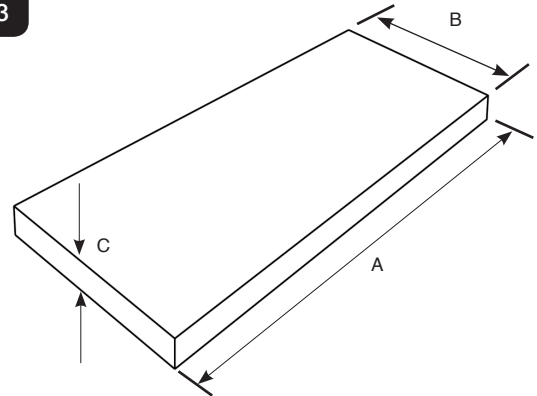

	Marlborough	Stockton	Manhattan
A	710	722	840
B	380	390	460
C	12	12	12

- 6.2 This appliance must be installed on an external wall.

Installation Instructions

Site Requirements

MINIMUM CLEARANCE

- 6.3 The appliance is not suitable for installation against a combustible wall. All combustible materials must be removed from behind the appliance.
- 6.4 **Ensure that all minimum clearances to combustible materials are complied with as shown in Diagrams 4 & 5.**

The specified clearances provide the minimum distance to combustible materials. If the appliance is intended to be installed into a non-combustible opening the clearance to the **sides and above** the appliance can be reduced. However, it is recommended that the specified clearances are maintained irrespective of the materials used in the construction of the opening to allow adequate air flow and access to controls. **The clearance at the rear of the appliance must always be a minimum of 50mm.**

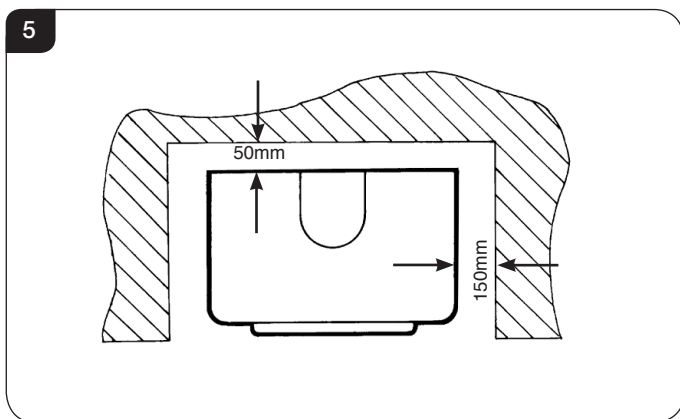
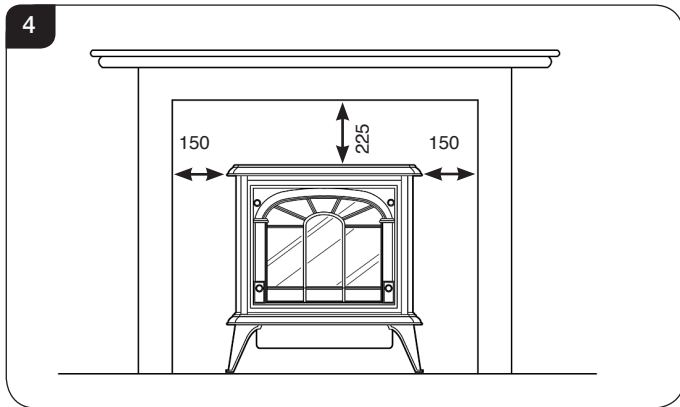

- 6.5 **In a non-combustible recess be careful to allow enough clearance at the sides and rear of the appliance to perform spillage tests and reach the controls.**

Installation Instructions

1. Safety Precautions



IMPORTANT: ALWAYS WEAR THE GLOVES PROVIDED WHEN HANDLING AN IVORY PAINTED APPLIANCE.

- 1.1 For your own and other's safety, you must install this appliance according to local and national codes of practice. Failure to install the appliance correctly could lead to prosecution. **Read these instructions before installing and using this appliance.**
- 1.2 These instructions must be left intact with the user.
- 1.3 Do not attempt to burn rubbish on this appliance.
- 1.4 Keep all plastic bags away from young children.
- 1.5 Do not place any object on or near to the appliance and allow adequate clearance above the appliance.

IF THE APPLIANCE IS EXTINGUISHED OR GOES OUT IN USE, WAIT 3 MINUTES BEFORE ATTEMPTING TO RELIGHT THE APPLIANCE.



IMPORTANT: REFER TO DATA BADGE AND TECHNICAL SPECIFICATION AT THE FRONT OF THE MANUAL TO ENSURE THE APPLIANCE IS CORRECTLY ADJUSTED FOR THE GAS TYPE AND CATEGORY APPLICABLE IN THE COUNTRY OF USE.

FOR DETAILS OF CHANGING BETWEEN GAS TYPES REFER TO SERVICING, SECTION 11, REPLACING PARTS.

Unpacking

- 1.6 Remove the appliance from its packaging, and check that it is complete and undamaged.

2. Upgrading the Appliance

- 2.1 The appliance is fitted with a control valve that can easily be upgraded to battery powered remote control. There are two versions of this control which can be obtained through your local Gazco retailer. There is no requirement for this upgrade to be carried out by an approved GasSafe engineer. However Gazco recommend that this task is undertaken by a suitably competent person.
- 2.2 This upgrade can be fitted before or after installation but if side clearances are limited then it will be easier to upgrade the appliance before installation. Full instructions are included with the kit.

Standard Remote Control (PART NUMBER 8455)

- 2.3 This remote control can control the gas appliance after the pilot has been lit. It can turn the main burner on and regulate it from low through to high and back again. It can turn the main burner off leaving the pilot burning.

Thermostatic and Timer Remote Control (PART NUMBER 8456)

- 2.4 This remote control can control the gas appliance after the pilot has been lit.

MANUAL MODE

Can be used to turn the main burner on and manually regulate it from low through to high and back again. It can also be used to turn the main burner off leaving the pilot burning.

AUTO MODE

Will automatically regulate the room to a pre-set temperature.

TIMER MODE

Will turn the appliance on and off according to a pre-set programme and automatically regulate the room temperature during the two on periods.

3. Installation of the Appliance



IMPORTANT: THE OUTER PANNELLING AND DOOR OF THE APPLIANCE IS MADE FROM CAST IRON OR STEEL. TAKE CARE WHEN INSTALLING, REMOVING AND STORING TO AVOID DAMAGING THE OUTER CASING, HEARTH OR DOOR.

- 3.1 The ceramic logs are located behind the door.

Marlborough & Stockton

- 3.2 Remove the 4 dome nuts retaining the door, see Diagram 1. Take care when removing the door as it is heavy. Place carefully to one side.

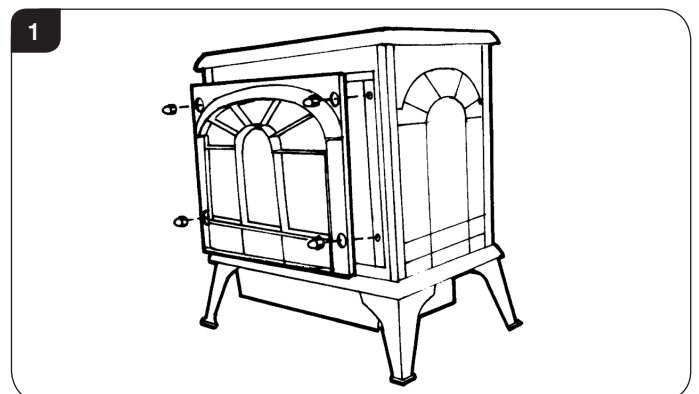

Remove the box and place in a safe location.

Installation Instructions

Steel Manhattan



THE GLASS FRAME IS FRAGILE. TAKE CARE WHEN HANDLING TO AVOID DAMAGE.

- 3.3 To remove the glass door lift off the decorative steel trim, see Diagram 2.

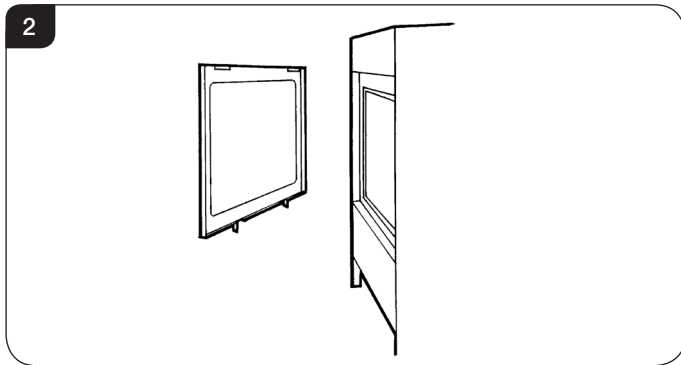

- 3.4 Remove the 8 screws holding the glass frame, see Diagram 3. Take care to support the glass when removing the screws.

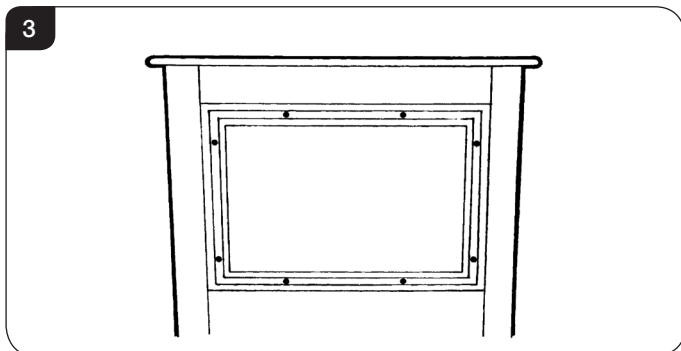

- 3.5 Remove the glass frame and place carefully to one side.
3.6 Remove the box and place in a safe location.

All Models

REFER TO SITE REQUIREMENTS SECTION FOR FLUE OPTIONS.

The appliance is suitable for rear flue exit only.

3A. Rear Exit Flue

- 3.7 Wall thickness: MIN = 200mm
MAX = 600mm
- 3.8 Unpack the adjustable flue assembly and terminal guard.
- 3.9 Do not lose the fixings.
- 3.10 Consider the final appliance position ensuring you comply with clearances required for the external flue, see Site Requirements, Section 1.
- 3.11 Mark the vertical centre-line of the appliance on the wall, see Diagram 4.
- 3.12 Mark the height from the top of the hearth to the centre of the flue, see Diagram 4, B.

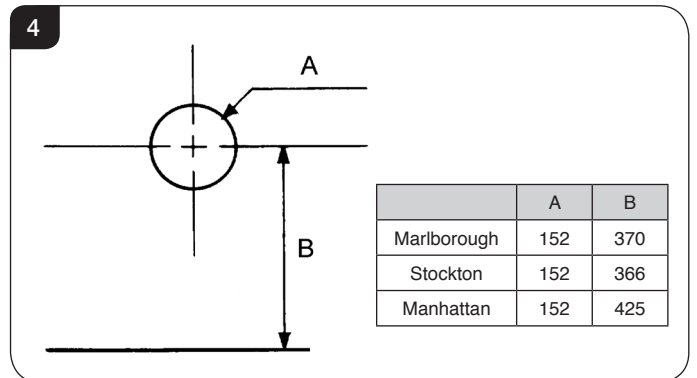

TAKE CARE WHEN MARKING OUT FOR THE FLUE. IT IS DIFFICULT TO MOVE AFTER INSTALLATION.

Flue Aperture

- 3.13 Create a 152mm (6") diameter hole for the flue using either:
- a core drill, or
 - a hammer and chisel

It is advisable to drill small holes around the circumference when using method b).

- 3.14 Make good at both ends of the hole.

Flue Length

- 3.15 Measure the total wall thickness and add 65mm.
- 3.16 The total flue length gives a minimum clearance of 50mm between the rear of the appliance and the wall.
- 3.17 Insert the square cardboard sleeve into the flue to support the inner tube.

Installation Instructions

3.18 Cut through the flue and sleeve, see Diagram 5.

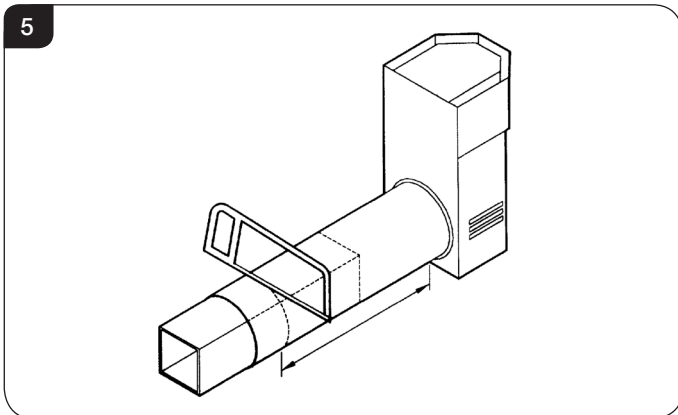

3.19 REMOVE THE CARDBOARD REMNANTS FROM THE FLUE.

3.20 File the cut edges smooth.

Terminal

On the outside wall:

3.21 Position the flue assembly into the hole. The terminal should be flat against the wall.

3.22 Make sure the terminal is vertical, see Diagram 6.

NOTE THE ORIENTATION OF THE TERMINAL, see Diagram 6.

3.23 Mark the four fixing holes.

3.24 Remove the terminal to drill the holes.

3.25 Insert wall plugs supplied.

DO NOT FIX THE FLUE AT THIS STAGE.

Flue and Appliance Fixings

3.26 Position the appliance observing appropriate clearances.

3.27 Apply a bead of suitable weatherproof sealant (silicone or similar) to perimeter of back face of terminal, see Diagram 6 B.

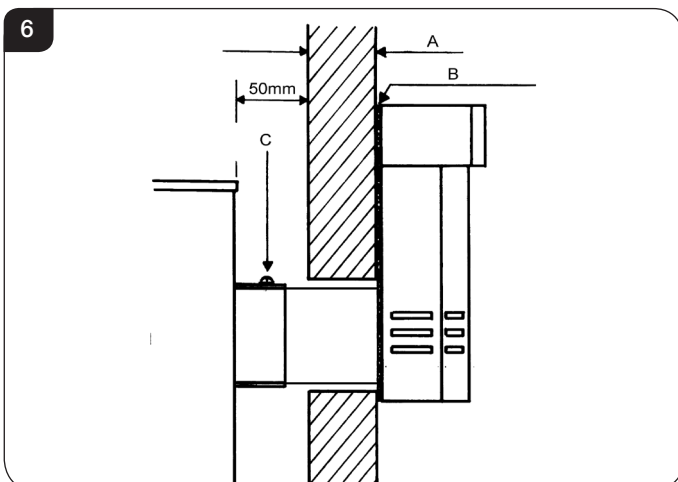

3.28 Feed the flue through the wall, making sure it runs smoothly.

On the inside wall:

3.29 Engage the flue in the inner and outer spigots.

3.30 Make sure rubber seals on the spigots are not damaged.

From outside:

3.31 Insert four screws in the flanges of the flue terminal.

3.32 Check sealant has formed a water-tight joint to the wall.

3.33 Any terminal less than 2m above any access (level ground, balcony or flat roof with access) must be fitted with the guard supplied, see Diagram 7.

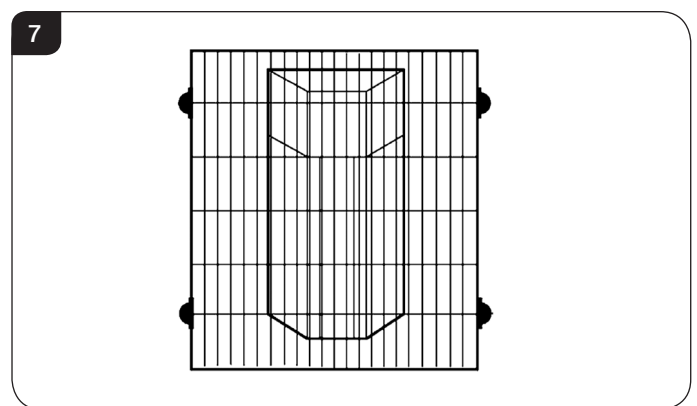

Steel Manhattan Stove Assembly

3.34 Open the second carton and carefully remove the steel casing components.

3.35 Remove the protective plastic coating from the 2 side assemblies.

3.36 Attach the 4 lugs to the front side of each panel and lower them onto the engine assembly until the tabs locate as shown.

3.37 Check the feet are touching the hearth, see Diagram 8.

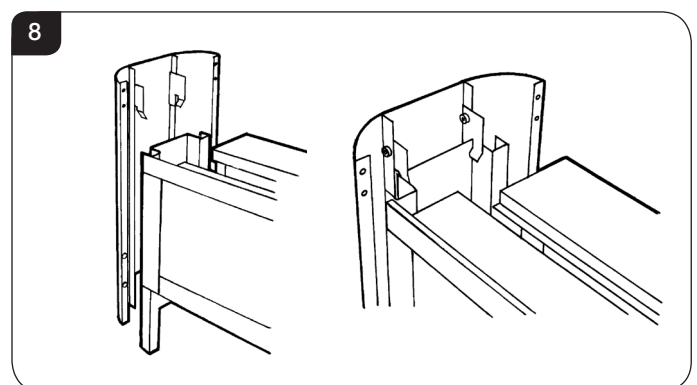

Installation Instructions

- 3.38 Secure the upper front panel using the 4 nuts and bolts provided, see Diagram 9.

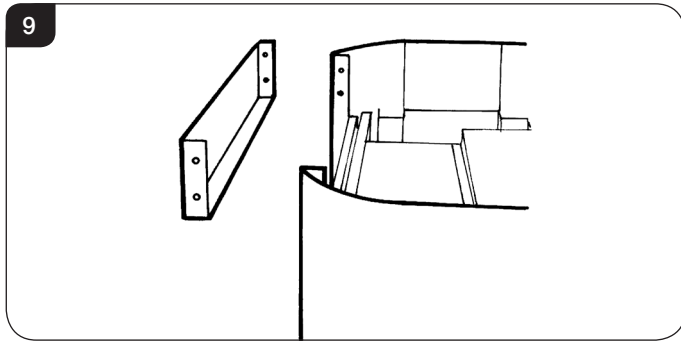

- 3.39 Locate the lower panels onto the lugs as shown, see Diagram 10.

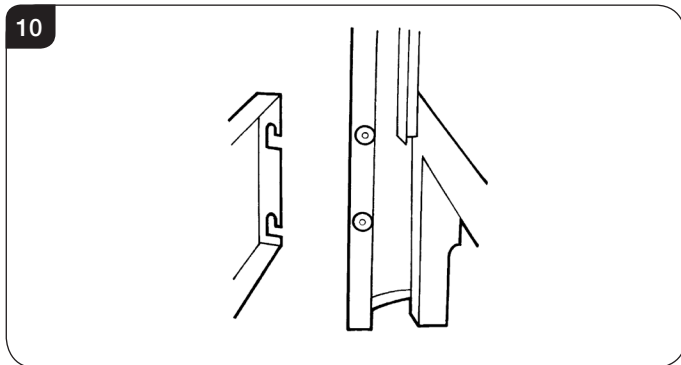

- 3.40 Place the steel top onto the casing so that the 2 lugs on the underside locate the top centrally within the casing. Place the cast iron grille into the recess in the centre of the top panel and locate the blanking plate into the grill (if required).

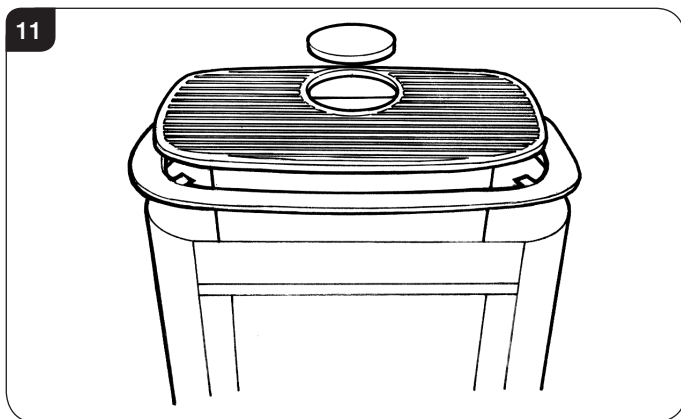

4. Gas Soundness Pressure Check

Having run the gas supply to the appliance, PURGE THE SUPPLY PIPE, this is essential to expel any debris that may block the gas controls.

- 4.1 Connect the gas to the 8mm elbow on the rear of the appliance, see Diagram 12.

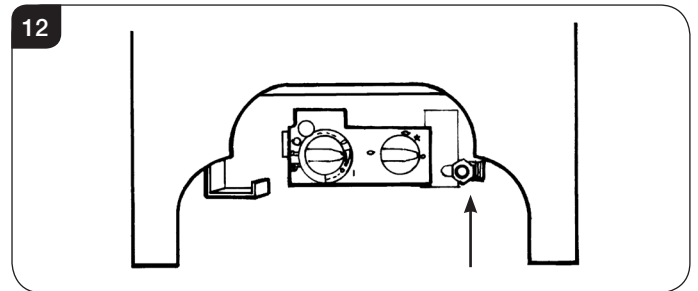

- 4.2 Connect a suitable pressure gauge to the test point located on the inlet fitting and turn the gas supply on. Light the appliance and check all gas joints for possible leaks. Turn the appliance to maximum and check that the supply pressure is as stated on the databadge. Turn the gas off and replace the test point screw, turn the gas on and check the test point for leaks.

5. Arrangement of Fuel Bed

Advice on handling and disposal of fire ceramics



The fuel effect and side panels in this appliance are made from Refractory Ceramic Fibre (RCF), a material which is commonly used for this application.

Protective clothing is not required when handling these articles, but we recommend you follow normal hygiene rules of not smoking, eating or drinking in the work area and always wash your hands before eating or drinking.

To ensure that the release of RCF fibres are kept to a minimum, during installation and servicing a HEPA filtered vacuum is recommended to remove any dust accumulated in and around the appliance before and after working on it. When servicing the appliance it is recommended that the replaced items are not broken up, but are sealed within heavy duty polythene bags and labelled as RCF waste.

RCF waste is classed as stable, non-reactive hazardous waste and may be disposed of at a licensed landfill site.

Excessive exposure to these materials may cause temporary irritation to eyes, skin and respiratory tract; wash hands thoroughly after handling the material.

Installation Instructions

6. Log Layout

- 6.1 There are 4 logs, each with an identification letter, A, B, C and D. Log C has an arrow on the underside to indicate its orientation. The arrow points towards the rear of the appliance.
- 6.2 Place the largest log A on the burner with the location legs on the underside against the stops on the rear of the burner skin, see Diagram 13.

13

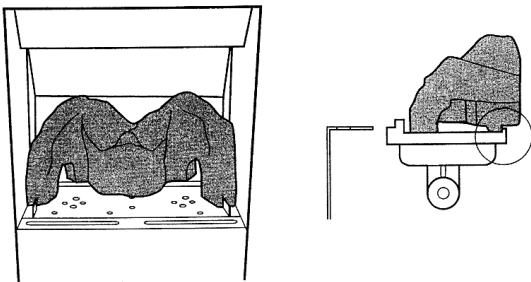

- 6.3 Place the rear face of log B against the stops on the front of the burner skin. The front of the log will rest on the firebox behind the two slots, see Diagram 14.

14

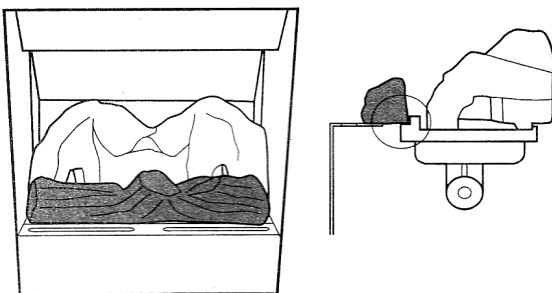

- 6.4 Place log C with the arrow pointing towards the rear of the appliance. The front of the log will rest in the hollow on the left-hand side of log B. The rear of the log will locate in the left-hand hollow on log A, see Diagram 15.

15

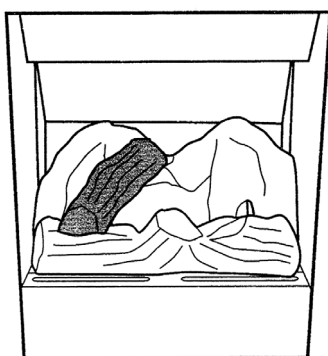

- 6.5 Log D is placed with the Y shaped branch towards the front of the appliance. There is a cutout on the top right hand side of the front log (B). Locate the right hand branch of log D in this cut-out and rest the top of the log in the location of log A, see Diagram 16.

16

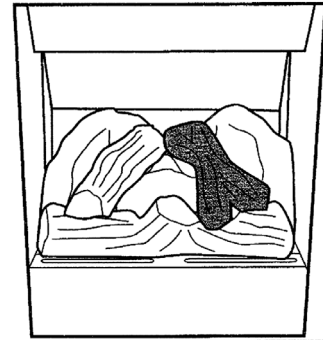

NOTE: ENSURE THAT LOGS ARE POSITIONED AS DETAILED ABOVE.

7. Replacing the Door

Marlborough & Stockton

- 7.1 Ensure that the rope seal on the back of the door is intact, locate the door on the four studs and slide back to the firebox. Secure in place using the 4 dome nuts. Do not overtighten the nuts, see Diagram 17.

17

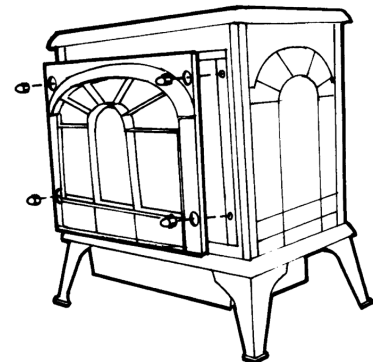

NEVER OPERATE THE APPLIANCE WHEN THE DOOR IS REMOVED, OR THE GLASS IS BROKEN.

- 7.2 Replace ALL of the securing nuts ensuring that a nut is present on all fixing studs.



UNDER NO CIRCUMSTANCES SHOULD THE APPLIANCE BE USED IF ANY OF THE DOOR RETAINING NUTS ARE LOOSE OR MISSING.

Installation Instructions

Steel Manhattan

- 7.3 Ensure that the rope seal on the back of the glass frame is intact. Replace the glass frame and tighten the 8 screws evenly, see Diagram 18. **DO NOT OVERTIGHTEN.**

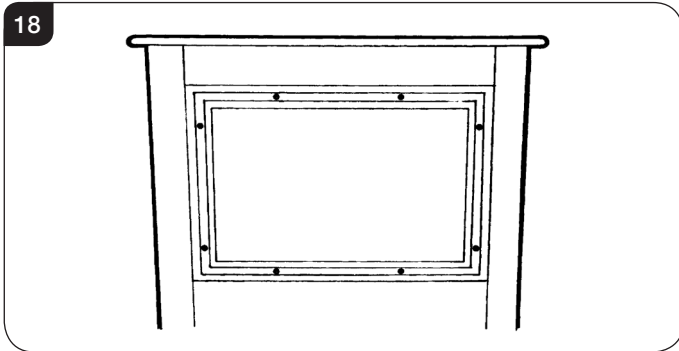

- 7.4 Offer the decorative steel trim to the opening, inserting the 2 tags on the bottom of the trim behind the bottom panel. Lift the top of the trim up and hook the lugs on the back of the trim over the top of the glass frame, see Diagram 19.

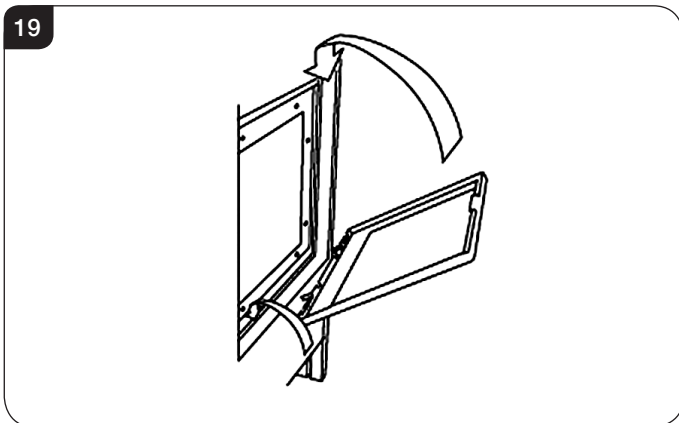

NEVER OPERATE THE APPLIANCE WHEN THE GLASS FRAME IS REMOVED, OR THE GLASS IS BROKEN.

- 7.5 Replace ALL of the securing screws and nuts ensuring that a screw is present in all fixing slots.



UNDER NO CIRCUMSTANCES SHOULD THE APPLIANCE BE USED IF ANY OF THE FRAME RETAINING SCREWS ARE LOOSE OR MISSING.

8. Operating the Appliance

- 8.1 Locate the control valve on the appliance. It has two controls, see Diagram 20:

1. The right-hand knob controls the pilot ignition.
2. The left-hand knob controls the main burner.

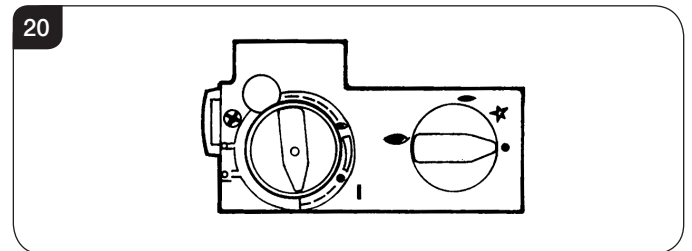

- 8.2 Refer to separate instructions if your appliance is upgraded to include battery remote control. The instructions below apply whether or not you have the remote upgrade.

Lighting the Pilot

- 8.3 To start the left-hand and right-hand control knobs must both point to off (●):

- 8.4 Press in the right-hand control knob and rotate anti-clockwise until a click is heard. Continue to press in. The knob points to the pilot (←).

The pilot is lit.

- 8.5 Keep the knob depressed for 10 seconds before releasing. The pilot remains lit.

Repeat the above steps if the pilot does not stay lit.

NOTE: If the pilot goes out, the Interlock system prevents you lighting again for a short period.

- 8.6 If, after repeating the above steps the pilot does not light, contact your Retailer or Installer.

- 8.7 Turn the right-hand knob to the left to main burner setting (←).

Adjusting the Flame height

- 8.8 You can now adjust the flame height and temperature using the left-hand control knob.

- 8.9 Turn the left-hand knob anti-clockwise to increase the flame height.

- 8.10 Turn clockwise to decrease the height.



IMPORTANT: YELLOW FLAMES TYPICALLY APPEAR WHEN THE APPLIANCE HAS REACHED NORMAL OPERATING TEMPERATURE. THIS CAN TAKE UP TO 30 MINUTES.



WARNING: IF THE APPLIANCE FAILS TO LIGHT OR BECOMES EXTINGUISHED IN USE, WAIT 3 MINUTES BEFORE ATTEMPTING TO RELIGHT.

1. Commissioning

- 1.1 Complete the Commissioning Checklist at the front of this manual covering:
 - Flue checks.
 - Gas checks.
 - Log layout - flame picture.
- 1.2 Ensure all safety checks listed in the Commissioning Section are completed, paying particular attention to the glass panel checks and securing of the door.
- 1.3 Upon completion of the commissioning and testing of the installation and correct operation of the appliance, the installer must instruct the user how to operate the appliance.
- 1.4 Guide the user through the User Instructions paying particular attention to:
 - a) Regular servicing (Section 12 of the User Instructions).
 - b) Ventilation (Section 13 of the User Instructions) - point out the ventilation positions where applicable.
 - c) Hot surfaces (Section 15 of the User Instructions).

Servicing Instructions

Servicing/Fault Finding Charts

1. Servicing Requirements

IMPORTANT – The glass panel on this appliance should be checked for any signs of damage on the front face of the glass panel (scratches, scores, cracks or other surface defects). If damage is observed, the glass panel must be replaced and the appliance must not be used until a replacement is installed. Under no circumstances should the appliance be used if any damage is observed. Please isolate the appliance until a replacement glass panel has been obtained and installed. Replacement glass panels can be purchased from Gazco via the retailer from which the appliance was purchased or any other Gazco distributor.

This appliance must be serviced at least once a year by a competent person.

All tests must be carried out in accordance with the current GasSafe recommendations.

1.1 Before Testing:

- Conduct a gas soundness test for the property ensuring there are no leaks before servicing.
- Check the operation of the appliance before testing.

1.2 Special checks:

- Clean the burner using a vacuum cleaner with a soft brush attachment. Ensure all debris is removed from the burner ports.
- Clean any lint or fluff from the pilot - pay particular attention to the aeration holes of the pilot.
- Clean away lint or fluff from under the burner.
- Check the spark gap on the pilot is correct, see Diagram 1.
- Ensure that the glass frame/ door is secured correctly and that all retaining screws or nuts are in place.

1.3 Correct any faults found during the initial test.

1.4 Re-commission the appliance in accordance with Commissioning Procedures.

1.5 Advise the customer of any remedial work undertaken.

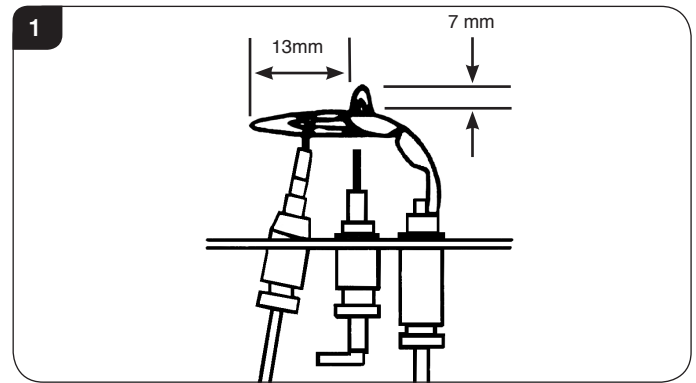

IGNITION FUNCTIONAL CHECK 1

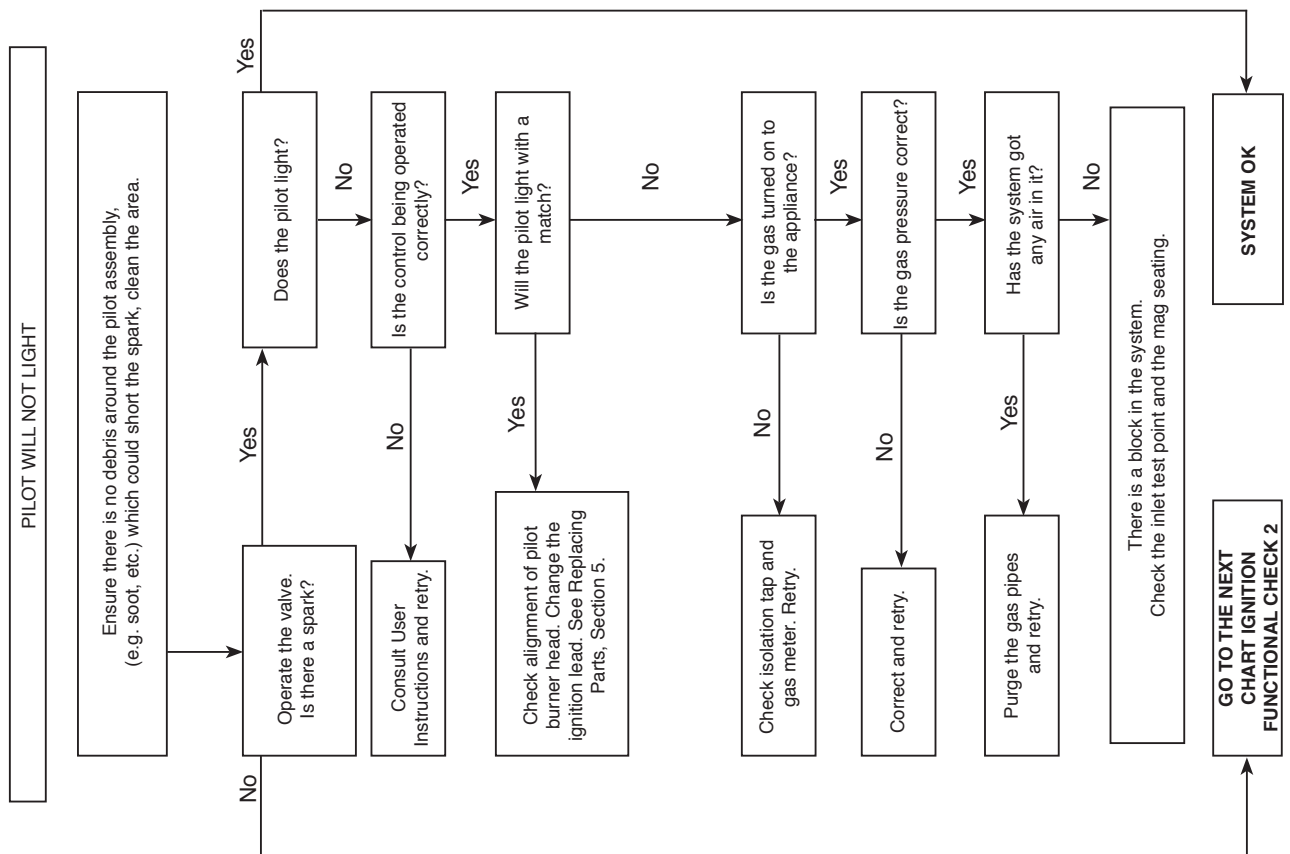

Servicing Instructions

Fault Finding Charts

FLAME FAILURE FUNCTIONAL CHECK 3

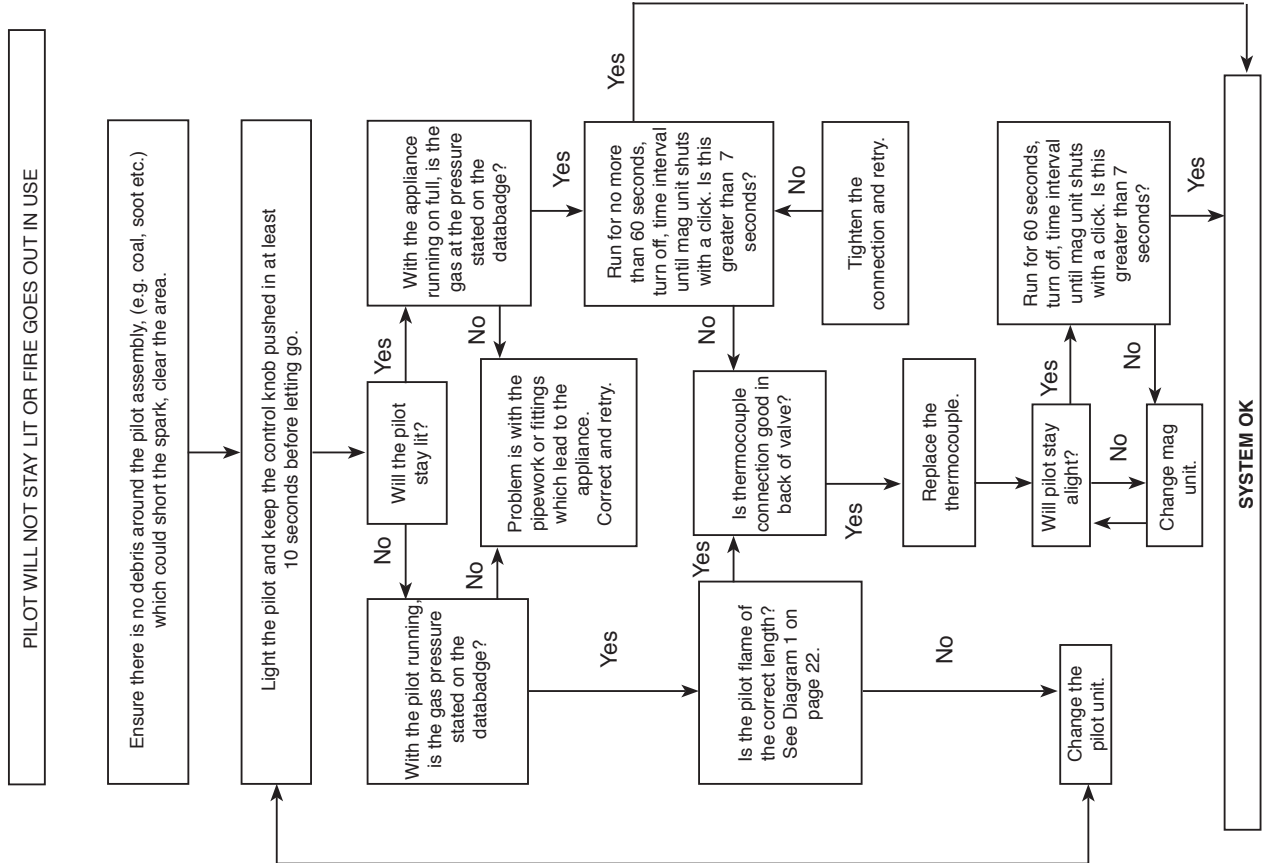

IGNITION FUNCTIONAL CHECK 2

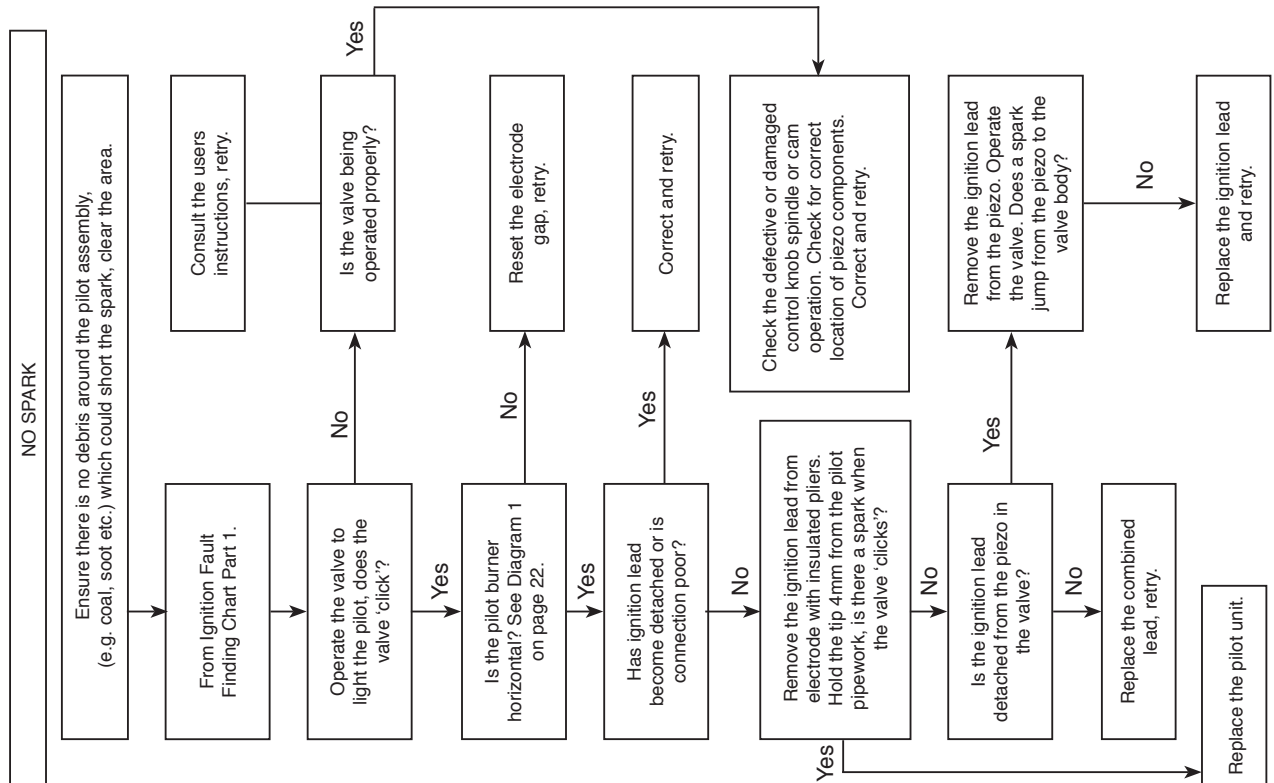

Servicing Instructions - Replacing Parts

1. General



IMPORTANT: ALWAYS WEAR THE GLOVES PROVIDED WHEN HANDLING AN IVORY PAINTED APPLIANCE.

- 1.1 All main components can be replaced without removing the appliance from its installation.
- 1.2 Ensure the appliance and surrounds are cool before servicing.

IT IS ESSENTIAL THAT THE GAS SUPPLY TO THE APPLIANCE IS TURNED OFF AT THE ISOLATION DEVICE BEFORE PROCEEDING FURTHER.

- 1.3 If, for any reason, the flue has to be removed from the appliance, the seals must be replaced.

2. Removing the Door



IMPORTANT: THE OUTER PANNELLING AND DOOR OF THE APPLIANCE IS MADE FROM CAST IRON OR STEEL. TAKE CARE WHEN INSTALLING, REMOVING AND STORING TO AVOID DAMAGING THE OUTER CASING, HEARTH OR DOOR.

Marlborough & Stockton

- 2.1 Remove the cast iron door by removing the 4 dome nuts retaining the door. Place carefully to one side.

1

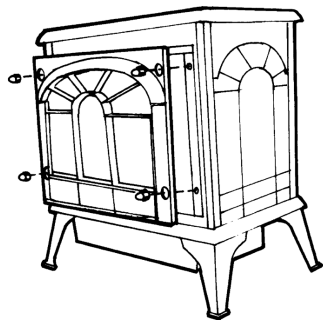

- 2.2 Refit in reverse order.
- 2.3 Ensure that the rope seal on the back of the door is intact, locate the door on the four studs and slide back to the firebox. Secure in place using the 4 dome nuts. Do not overtighten the nuts, see Diagram 1.

NEVER OPERATE THE APPLIANCE WHEN THE DOOR IS REMOVED, OR THE GLASS IS BROKEN.

- 2.4 Replace ALL of the securing nuts ensuring that a nut is present on all fixing studs.



UNDER NO CIRCUMSTANCES SHOULD THE APPLIANCE BE USED IF ANY OF THE DOOR RETAINING NUTS ARE LOOSE OR MISSING.

Steel Manhattan



THE GLASS FRAME IS FRAGILE. TAKE CARE WHEN HANDLING TO AVOID DAMAGE.

- 2.5 To remove the glass door lift off the decorative steel trim, see Diagram 2.

2

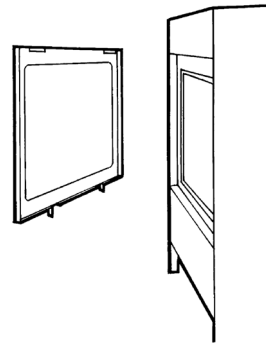

- 2.6 Remove the 8 screws holding the glass frame, see Diagram 3. Take care to support the glass when removing the screws.

3

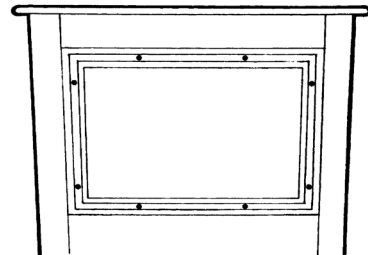

- 2.7 Remove the glass frame and place carefully to one side.
- 2.8 Refit in reverse order.
- 2.9 Ensure that the rope seal on the back of the glass frame is intact. Replace the glass frame and tighten the 8 screws evenly, see Diagram 3. **DO NOT OVERTIGHTEN.**
- 2.10 Offer the decorative steel trim to the opening, inserting the 2 tags on the bottom of the trim behind the bottom panel. Lift the top of the trim up and hook the lugs on the back of the trim over the top of the glass frame, see Diagram 4.

4

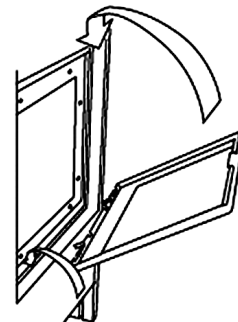

NEVER OPERATE THE APPLIANCE WHEN THE DOOR IS REMOVED, OR THE GLASS IS BROKEN.

Servicing Instructions - Replacing Parts

- 2.11 Replace ALL of the securing screws ensuring that a screw is present in all fixing slots.



UNDER NO CIRCUMSTANCES SHOULD THE APPLIANCE BE USED IF ANY OF THE DOOR RETAINING SCREWS ARE LOOSE OR MISSING.

3. Main Burner

- 3.1 Turn the gas supply off at the isolation device, remove the door and place to one side, carefully remove the ceramic fuel bed components.
- 3.2 Remove the 3 securing screws, 2 at the rear and 1 at the front left hand side, see Diagram 5.
- 3.3 Raise the left hand side of the burner to clear the bracket, draw the left hand side forward.

The burner venturi is engaged over the injector. When removing the burner be sure to clear the injector, this will release the right hand side of the burner.

Take care when removing the burner so as not to damage the pilot burner.

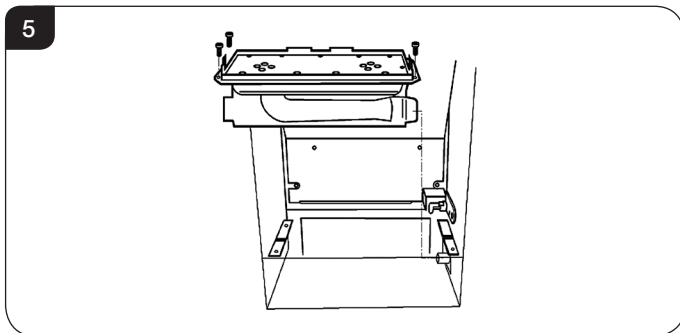

- 3.4 To replace the burner, engage the venturi over the injector ensuring the burner sits on top of the fixing bracket. Push the burner to the right and whilst holding, insert the three fixing screws.

NOTE: BEFORE REPLACING THE BURNER, ENSURE THE SILICONE SEAL AROUND THE INJECTOR IS INTACT AND CHECK THAT VENTURI COVER IS ATTACHED.

4. Pilot Unit

The pilot assembly consists of five components, which can be individually changed, these are:

- 4a) Pilot burner bracket.
- 4b) Pilot injector.
- 4c) Electrode.
- 4d) Thermocouple.
- 4e) Gasket.

- 4.1 Turn the gas supply off at the isolation device, remove the door and place to one side, carefully remove the ceramic fuel bed components.

4a. Pilot Burner Bracket

- 4.2 Remove the 2 fixing screws from the pilot bracket, see Diagram 6. Gently draw the assemble away from the firebox to give access to the nuts and ignition lead.

NOTE: TAKE CARE NOT TO DAMAGE THE GASKET.

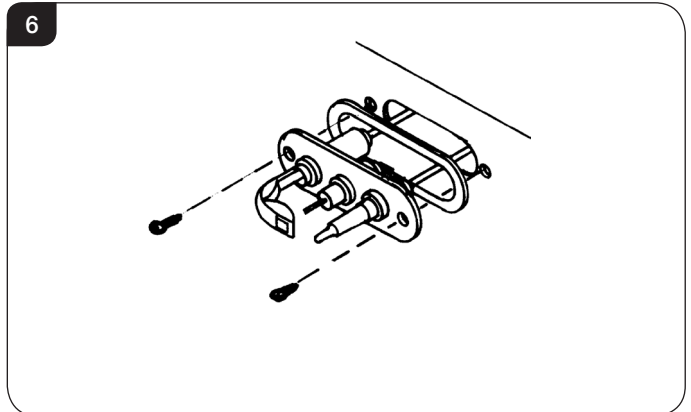

4b. Pilot Injector

- 4.3 Undo the compression nut on the pilot feed pipe and withdraw the injector which will be hooked onto the olive. When replacing an injector always make sure it is hooked onto the olive before inserting it into the pilot burner, see Diagram 7.

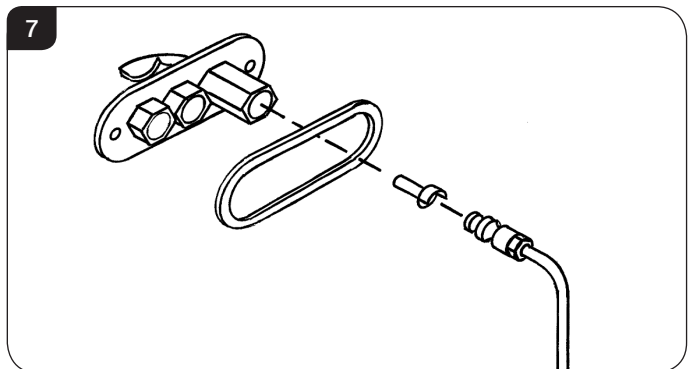

4c. Electrode

- 4.4 Disconnect the ignition lead and undo the retaining nut. The electrode can now be removed, note the orientation of the electrode terminal when reassembling, see Diagram 8.

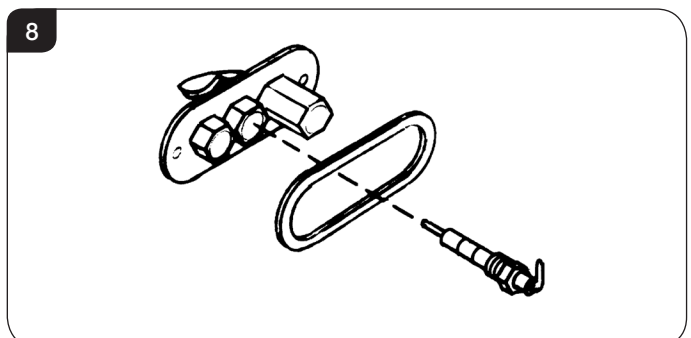

Servicing Instructions - Replacing Parts

4d. Thermocouple

- 4.5 Undo the retaining nut and withdraw the thermocouple, see Diagram 9.

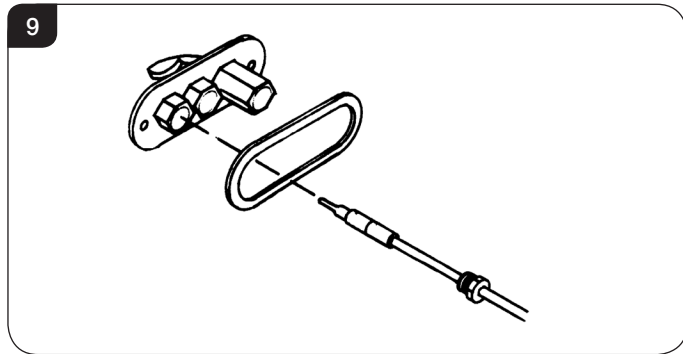

- 4.6 Undo the thermocouple from the back of the gas valve, see Diagram 10.

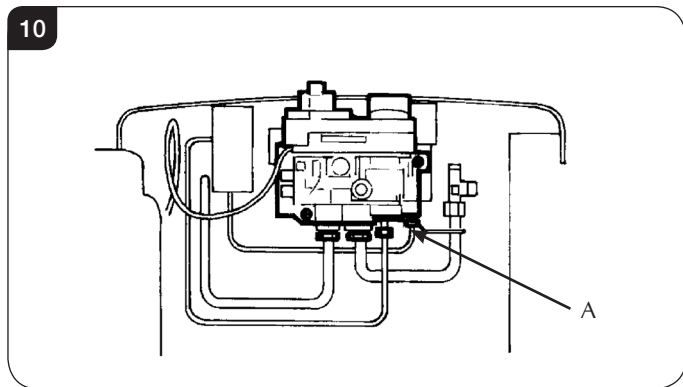

- 4.7 Reassemble in reverse order. Do not overtighten.

4e. Gasket

- 4.8 Disconnect all the above components and withdraw the gasket. If it is damaged, replace with a new item. **Always replace the gasket first when reassembling the pilot components.**

5. Ignition Lead

- 5.1 To access the back of the pilot assembly, see Section 3.
5.2 Disconnect the ignition lead from the electrode.
5.3 Remove the front cover from the control valve by removing the retaining screw, see Diagram 11 and gently levering clear with flat bladed screwdriver, see Diagram 12.

NOTE: There is a small cylindrical metal spacer inside the cover, this must be kept and replaced on the fixing screw on re-assembly.

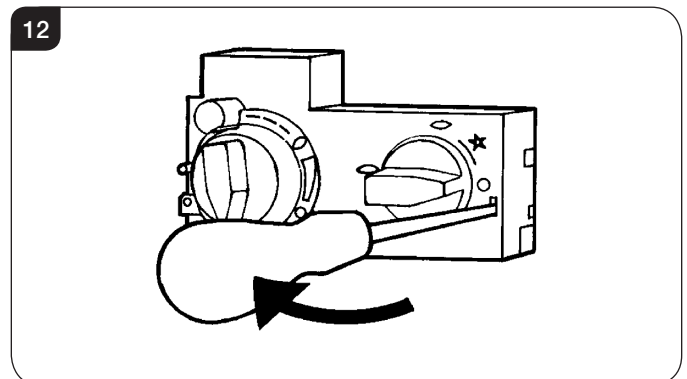
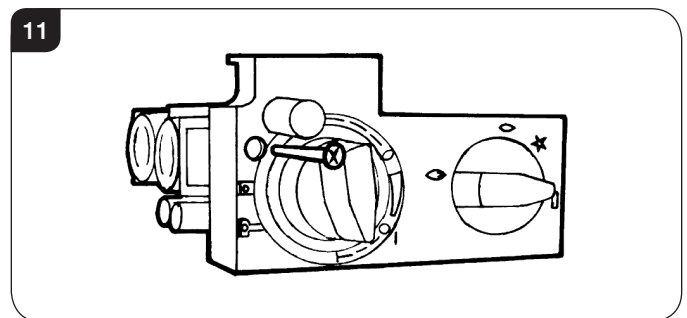

- 5.4 Disconnect the end of the ignition lead from the valve body, see Diagram 13, Arrow B, note the existing route of the ignition lead.

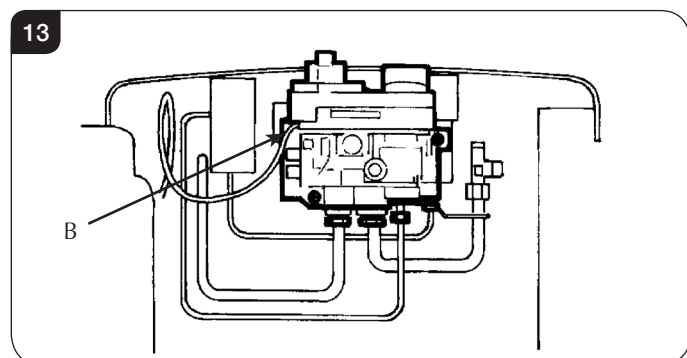

- 5.5 Replace with a new ignition lead following the same route as the old one.

Replace the valve cover and the pilot assembly.

- 5.6 Check operation of the new ignition lead.

Servicing Instructions - Replacing Parts

6. Piezo

- 6.1 The piezo assembly used on this appliance is not serviceable and is not likely to fail.
- 6.2 If a new piezo is required it will be necessary to change the valve, see Section 7.

7. Gas Valve

- 7.1 Turn the gas supply off at the isolation device.
- 7.2 Disconnect the 2 x 8mm and 1 x 4mm gas pipe fittings at the back of the gas valve and also disconnect the thermocouple, see Diagram 14, Arrow A.
- 7.3 Remove the control valve cover and disconnect the ignition lead from the gas valve, see Section 5.
- 7.4 Undo the two bolts securing the gas valve to the appliance and remove the valve, see Diagram 14, Arrow C.
- 7.5 Replace in reverse order.
- 7.6 Check all joints for gas leaks.
- 7.7 Check operation of thermocouple and ignition lead.

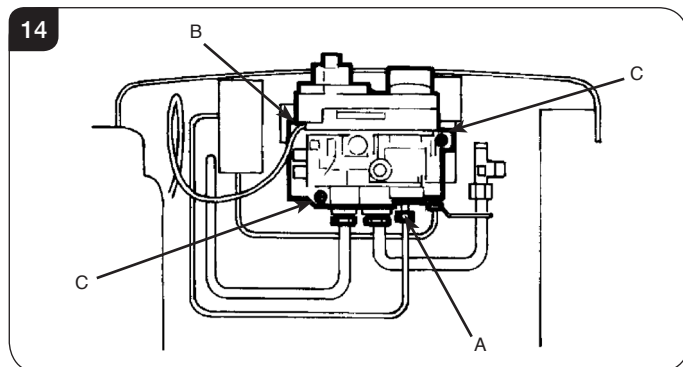

8. Magnetic Safety Valve

- 8.1 Turn the gas supply off at the isolation device. Undo the thermocouple connection from the back of the gas valve.
- 8.2 Undo the mag valve retaining nut at the back of the control valve, gently tap out the mag valve and replace with a new unit. Replace the retaining nut and tighten, see Diagram 14, Arrow A.
- 8.3 Secure the thermocouple in the rear of the gas control. (Do not over tighten). Turn the gas supply on and check the entire pipe work and valve joints for any leaks.

9. Main Injector

- 9.1 Turn the gas supply off at the isolation device.
- 9.2 Remove the main burner, see Section 3.
- 9.3 Undo the compression nut from the feed pipe at the gas control under the appliance.
- 9.4 Working from inside the firebox, remove the lock nut from the injector, see Diagram 15 and withdraw the injector complete with the feed pipe from under the appliance.

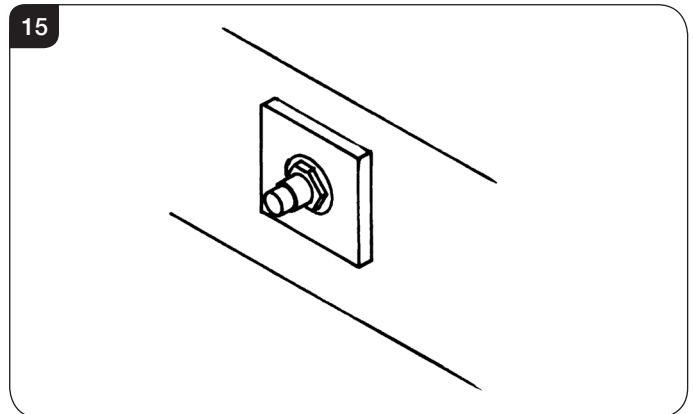

- 9.5 Holding the injector with a spanner, undo the feed pipe. **NOTE: THE ORIENTATION OF THE INJECTOR.**
- 9.6 Reassemble in reverse order,
- 9.7 Turn on the gas supply and check for any leaks.

10. Primary Aeration Plate

- 10.1 Turn the gas supply off at the isolation device.
- 10.2 Remove the main burner, see Section 3.
- 10.3 Remove the 2 screws on the burner skin to detach the venturi cover from the venturi. Slide the venturi cover off the venturi, see Diagram 16.

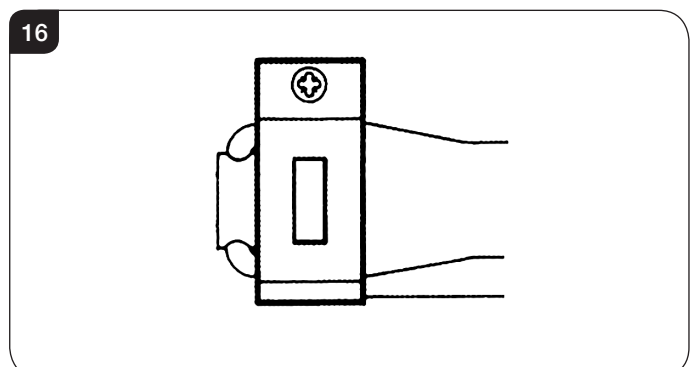

- 10.4 Refer to the technical specification and databadge to check the gas type and its required aeration plate. Change the aeration plate, if necessary.
- 10.5 Reassemble in reverse order with correct aeration plate(s).

Servicing Instructions - Replacing Parts

11. Changing Between Gas Types

In order to change between gas types it will be necessary to change both the burner assembly and the complete control assembly.

Contact your Gazco retailer for further information.

A kit of parts is available for this. Always quote the Model number and Serial number when ordering any spare parts.

12. Control Upgrade

See Installation Instructions, Section 2.

Servicing Instructions - Replacing Parts

13. Spares List - Steel Manhattan

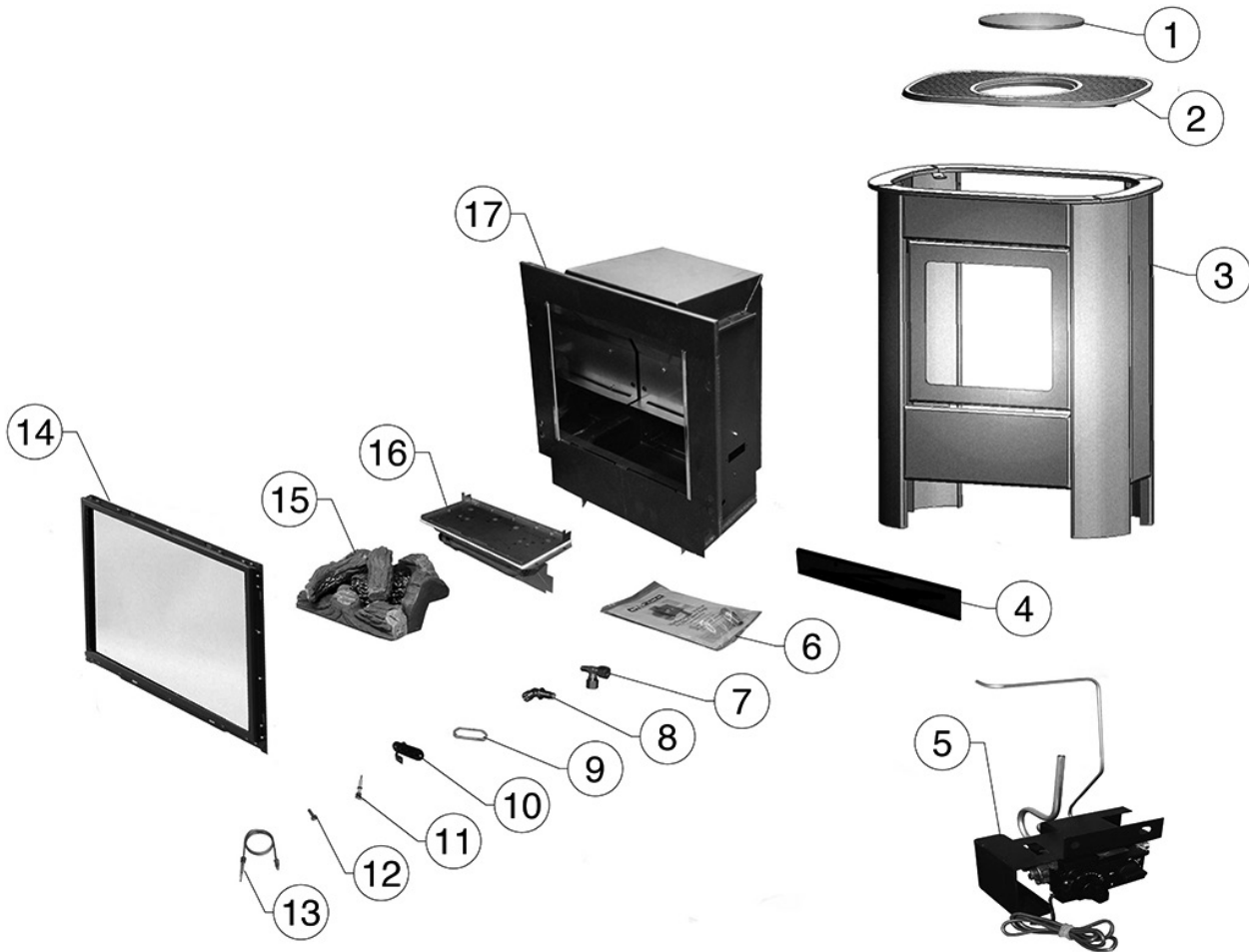

No.	Component	Part Code		Quantity
		Natural Gas	LPG	
1	Blanking Plate	CA0268		1
2	Grille	CA0567		1
3	Carcass Complete - Anthracite	GZ3703		1
	Carcass Complete - Brushed Steel	GZ3441		1
4	Skirt	GZ3637		1
5	Control Assembly	B0212		1
6	Instruction Kit	GZ3266	GZ3973	1
7	8mm Pressure Test Elbow	IN009		1
8	Elbow Injector	IN0041 - Size 225	IN0049 - Size 95	1
9	Pilot Gasket	PI0052		1
10	Pilot Body	PI0051		1
11	Electrode	PI0053		1
12	Pilot Injector	PI0026	PI0015	1
13	Thermocouple	PI0011		1
14	Glass Frame Assembly	GZ3447		1
15	Log Set	CE0369		1
16	Burner Assembly	GZ3312	GZ3635	1
17	Firebox Assembly	MEC0233		1

Servicing Instructions - Replacing Parts

13. Spares List - Marlborough Small

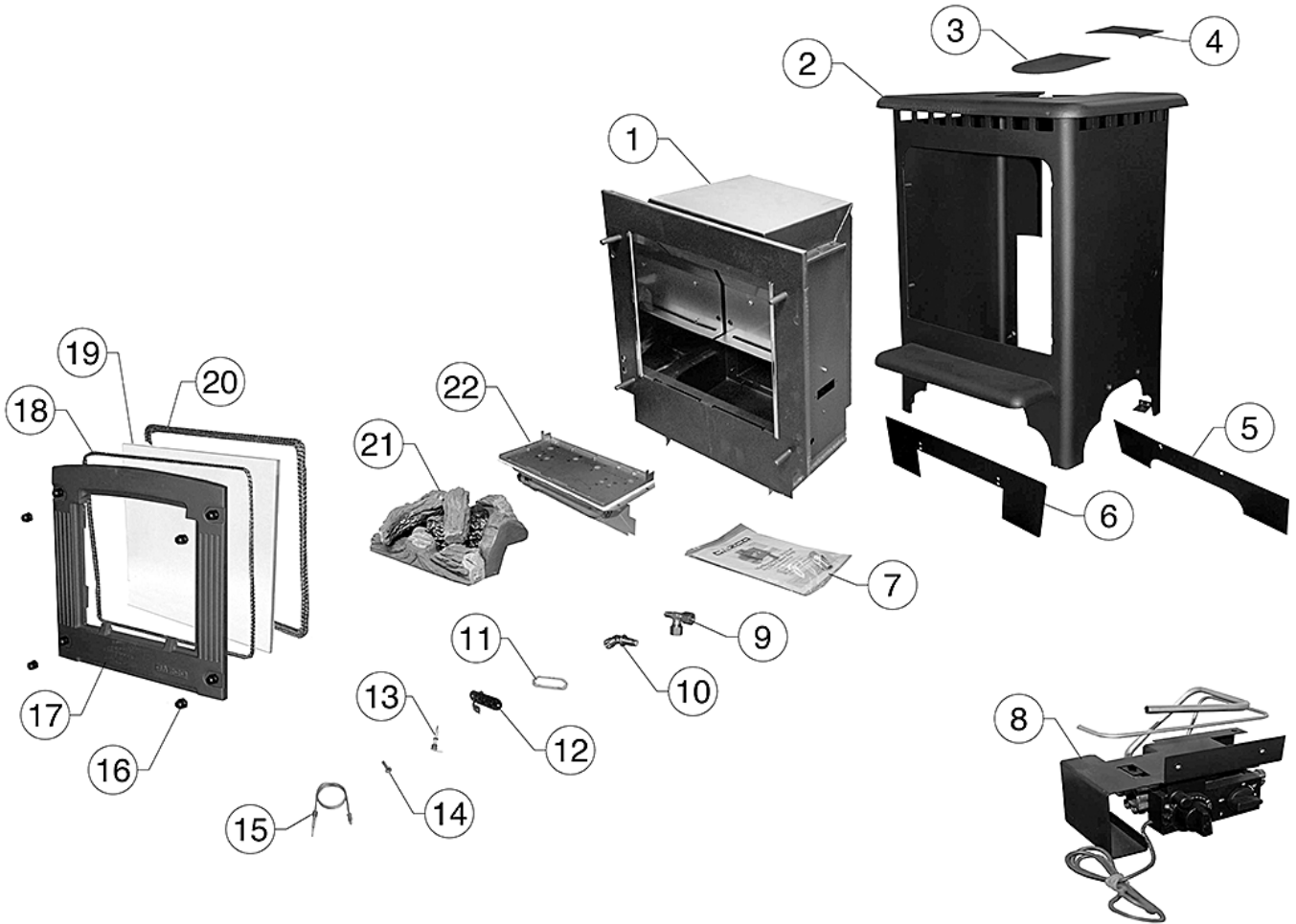

No.	Component	Part Code		
		Natural Gas	LPG	Quantity
1	Firebox Assembly	MEC0237		1
2	Carcass Assembly	GZ1138		1
3	Rear Exit Blanking Plate	MEC0097		1
4	Top Exit Blanking Plate	MEC0099		1
5	Skirt	GZ3615		1
6	Rear Airduct	GZ3658		1
7	Instruction Kit	GZ3773	GZ3972	1
8	Control Assembly	A8536	AP8536	1
9	Pressure Test Elbow	IN0009		1
10	Elbow Injector	Size 225 IN0041	Size 95 IN0049	1
11	Pilot Gasket	PI0052		1

No.	Component	Part Code		
		Natural Gas	LPG	Quantity
12	Pilot Body	PI0051		1
13	Electrode	PI0053		1
14	Pilot Injector	PI0026	PI0015	1
15	Thermocouple	PI0011		1
16	Black Dome Nuts	FA0259		4
17	Cast Door	CA0215		1
18	4mm Diameter Ropeseal	FA0136		1
19	Glass Panel	CE0134		1
20	12mm Diameter Ropeseal	FA0135		1
21	Log Set	CE0369		1
22	Burner	GZ3312	GZ3635	1

Due to continual technical improvements please check online at www.gazcospares.com or with your Gazco retailer for the most up to date parts lists.

Servicing Instructions - Replacing Parts

13. Spares List - Stockton Small

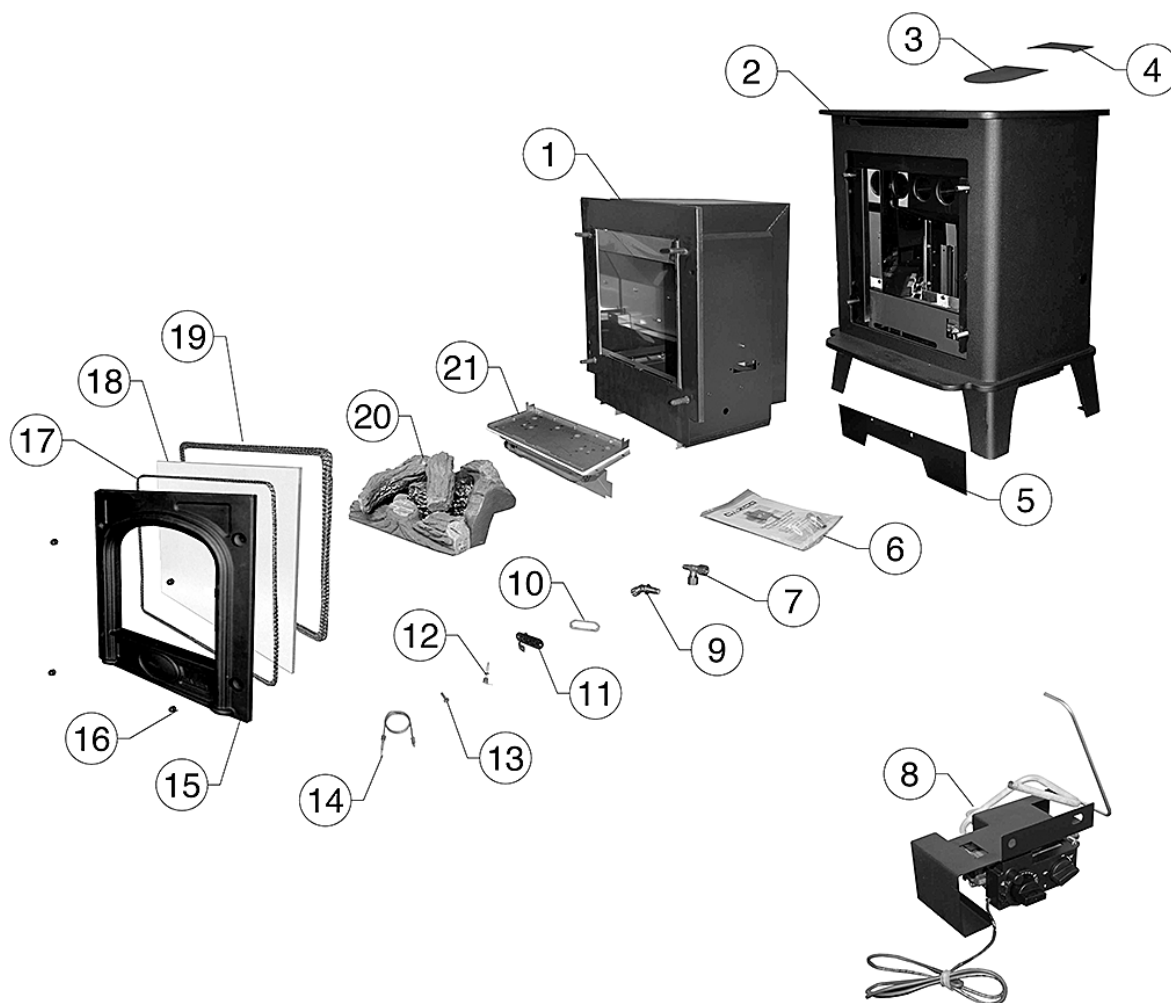

No.	Component	Part Code		Quantity
		Natural Gas	LPG	
1	Firebox Assembly	MEC0238		1
2	Carcass Assembly	GZ3327		1
3	Rear Exit Blanking Plate	GZ3330		1
4	Top Exit Blanking Plate	GZ3331		1
5	Skirt	GZ3605		1
6	Instruction Kit	GZ3773	GZ3972	1
7	Pressure Test Elbow	IN0009		1
8	Control Assembly	B0211		1
9	Elbow Injector	Size 225 IN0041	Size 95 IN0049	1
10	Pilot Gasket	PI0052		1
11	Pilot Body	PI0051		1

No.	Component	Part Code		Quantity
		Natural Gas	LPG	
12	Electrode	PI0053		1
13	Pilot Injector	PI0026	PI0015	1
14	Thermocouple	PI0011		1
15	Door Casting	CA0559		1
16	Black Dome Nuts	FA0259		4
17	4mm Diameter Ropeseal	FA0136		1
18	Glass Panel	CE0195		1
19	12mm Diameter Ropeseal	FA0135		1
20	Log Set	CE0369		1
21	Burner	GZ3312	GZ3635	1

Servicing Instructions - Replacing Parts

13. Spares List - Control Assembly - All Models



No.	Component	Part Code		
		Natural Gas	LPG	Quantity
1	Control Valve	GC0088K		1
2	Control Valve Cover	GC0087		1
3	Magnetic Unit	GC0166		1
4	Micro Switch & Screw	EL0241		1
5	Standard Handset	EL0239		1
6	Thermostatic Handset	EL0240		1
7	Standard Receiver	EL0235		1
8	Thermostatic Receiver	EL0236		1
9	Thermostatic Receiver Cable	EL0238		1
10	Standard Receiver Cable	EL0237		1
11	Geared Motor	EL0234		1
12	Ignition Lead	GC0090		1

Service Records

1ST SERVICE

Date of Service.....
Next Service Due
Signed
Retailer's Stamp/GasSafe Registration Number

2ND SERVICE

Date of Service.....
Next Service Due
Signed
Retailer's Stamp/GasSafe Registration Number

3RD SERVICE

Date of Service.....
Next Service Due
Signed
Retailer's Stamp/GasSafe Registration Number

4TH SERVICE

Date of Service.....
Next Service Due
Signed
Retailer's Stamp/GasSafe Registration Number

5TH SERVICE

Date of Service.....
Next Service Due
Signed
Retailer's Stamp/GasSafe Registration Number

6TH SERVICE

Date of Service.....
Next Service Due
Signed
Retailer's Stamp/GasSafe Registration Number

7TH SERVICE

Date of Service.....
Next Service Due
Signed
Retailer's Stamp/GasSafe Registration Number

8TH SERVICE

Date of Service.....
Next Due
Signed
Retailer's Stamp/GasSafe Registration Number

9TH SERVICE

Date of Service.....
Next Service Due
Signed
Retailer's Stamp/GasSafe Registration Number

10TH SERVICE

Date of Service.....
Next Service Due
Signed
Retailer's Stamp/GasSafe Registration Number

Gazco Limited, Osprey Road, Sowton Industrial Estate, Exeter, Devon, England EX2 7JG
Technical Customer Services: (01392) 261950 Fax: (01392) 261951

A member of the Stovax Group
E & O E